

MAC 700 Profile

user manual



Dimensions

All measurements are expressed in millimeters

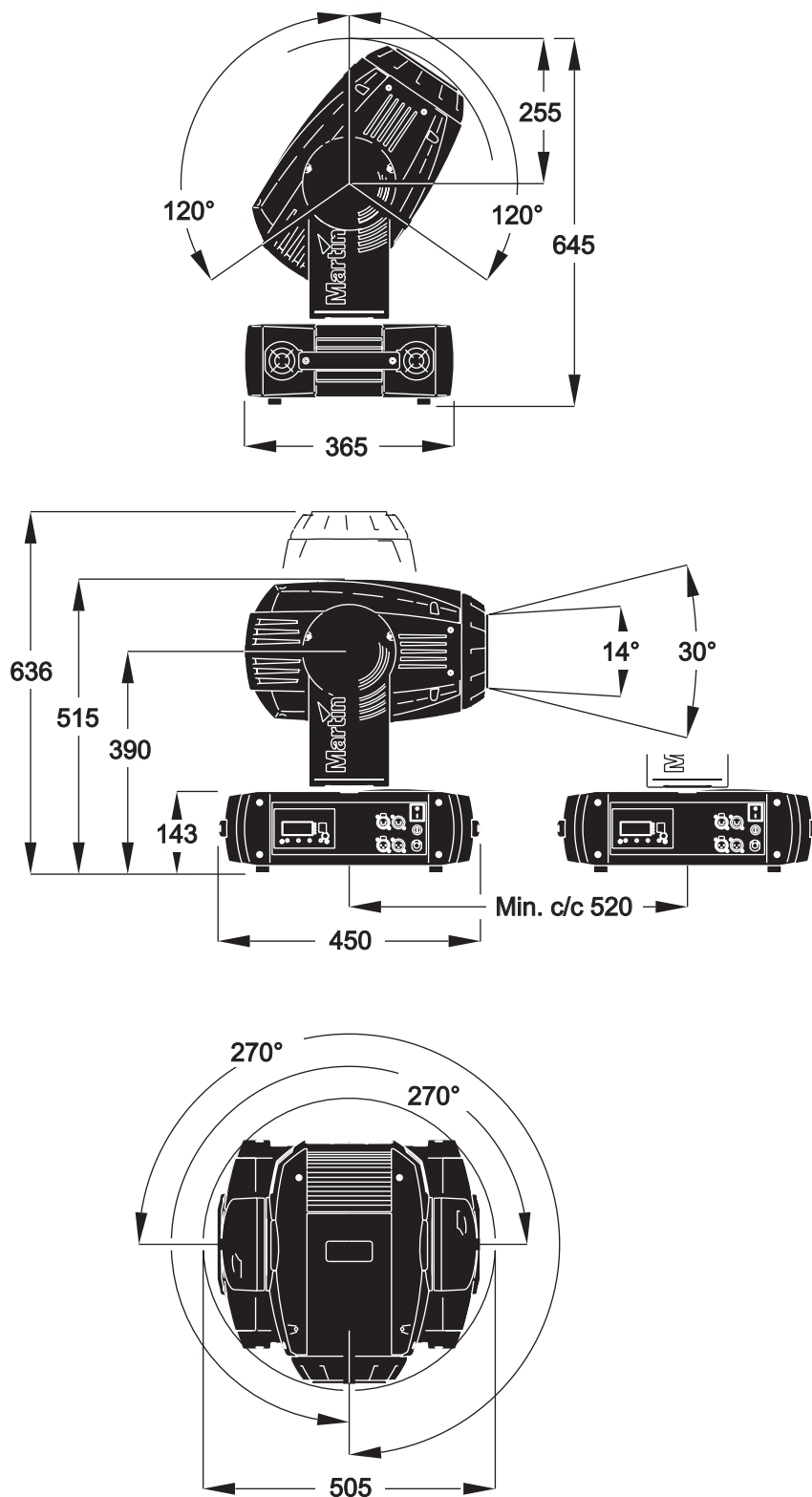

Contents

Introduction	5
Safety information	5
Unpacking	6
Using for the first time	6
AC power	7
Power supply and main fuse	7
Power connection	7
Lamp	8
About the discharge lamp	8
Lamp replacement	8
DMX data link	10
Tips for reliable data transmission	10
Rigging	11
Control panel	12
Menu navigation	12
DMX address and protocol	12
Tailoring performance	12
Readouts	13
Service messages	14
Manual control	14
Service utilities	14
Effects	16
Lamp power	16
Fixture reset	16
Dimming and strobe	17
Cyan, Magenta and Yellow	17
Color wheel	17
Rotating gobos	17
Static gobos	17
Gobo/color macros	17
Gobo animation	17
Prism and iris	17
Focus and zoom	18
Diffuser	18
Pan and tilt	18
Pan/tilt speed and effects speed channels	18
Optical configuration	19
Color wheel	19
Gobos	20
Animation wheel	22
Diffuser	23
Routine maintenance	24
Tilt lock	24
Disassembly	24
Cleaning	26
Lubrication	27
Software installation	27
MAC 700 Profile DMX protocol	29
Control menu	35
Adjustment submenu	39
Control menu shortcuts	40
Service messages	40
Display messages	41
Troubleshooting	42
Circuit board connections	43
MAC 700 Profile Specifications	44

This page is intentionally left blank

Introduction

Thank you for selecting the Martin MAC 700 Profile. This moving-head spotlight features:

- 700 Watt short-arc high-output discharge lamp with hot restrike
- full-range mechanical dimmer/shutter
- full-spectrum CMY color mixing
- 8 color filters including two color temperature correction filters
- six rotating gobos with 16-bit position indexing
- nine static gobos
- interchangeable gobo animation wheel
- three-facet rotating prism
- iris
- variable focus and zoom
- 540° of pan and 246° of tilt
- electronic “flicker-free” ballast
- auto-sensing switch-mode power supply.

For the latest firmware updates, documentation, and other information about this and all Martin Professional products, please visit the Martin website at <http://www.martin.com>

Comments or suggestions regarding this document may be e-mailed to service@martin.dk or posted to:

Service Department
Martin Professional A/S
Olof Palmes Allé 18
DK-8200 Aarhus N
Denmark

Warning! *Read the safety precautions in this manual before installing and operating the fixture.*

Safety information

Warning! *This product is for professional use only. It is not for household use.*

This product presents risks of lethal or severe injury due to fire and heat, electric shock, ultraviolet radiation, lamp explosion, and falls. **Read this manual** before powering or installing the fixture, follow the safety precautions listed below and observe all warnings in this manual and printed on the fixture. If you have questions about how to operate the fixture safely, please contact your Martin dealer or call the Martin 24-hour service hot line at +45 70 200 201.

PROTECTION FROM ELECTRIC SHOCK

- Disconnect the fixture from AC power before removing or installing the lamp, fuses, or any part, and when not in use.
- Always ground (earth) the fixture electrically.
- Do not use the fixture with a damaged power cable or cord cap.
- Use only a source of AC power that complies with local building and electrical codes and has both overload and ground-fault (earth-fault) protection.
- Do not expose the fixture to rain or moisture.
- Refer any service operation not described in this manual to a qualified technician.

PROTECTION FROM UV RADIATION AND LAMP EXPLOSION

- Do not operate the fixture with missing or damaged covers, shields, lenses or ultraviolet screens.

- Allow the fixture to cool for at least 45 minutes before opening the fixture or removing the lamp. Protect hands and eyes with gloves and safety glasses when handling lamps.
- Do not stare directly into the light. Never look at an exposed lamp while it is lit.
- Replace the lamp if it becomes visually deformed, damaged or in any way defective
- Replace the lamp before usage exceeds the maximum service life.

PROTECTION FROM BURNS AND FIRE

Danger! *Intense heat. Avoid contact by persons and materials.*

The exterior of the fixture can get very hot – up to 160° C (320° F). Allow the fixture to cool for at least 45 minutes before handling.

Prolonged exposure to an unshielded lamp can cause eye and skin burns.

- Never attempt to bypass the thermostatic switch or fuses. Always replace defective fuses with ones of the specified type and rating.
- Keep all combustible materials (for example fabric, wood, paper) at least 0.5 meters (20 inches) away from the fixture. Keep flammable materials well away from the fixture.
- Do not illuminate surfaces within 1.2 meters (42 inches) of the fixture.
- Provide a minimum clearance of 0.1 meters (4 inches) around fans and air vents.
- Never place filters or other materials over the lens.
- The exterior of the fixture can get very hot. Allow the fixture to cool for at least 45 minutes before handling.
- Do not modify the fixture or install other than genuine Martin parts.
- Do not operate the fixture if the ambient temperature (Ta) exceeds 40° C (104° F).

PROTECTION FROM INJURY DUE TO FALLS

- Do not lift or carry the fixture alone.
- When suspending the fixture, verify that the structure can hold at least 10 times the weight of all installed devices.
- Check that all external covers and rigging hardware are securely fastened and use an approved means of secondary attachment such as a safety cable.
- Block access below the work area and work from a stable platform whenever installing, servicing or removing the fixture.

Unpacking

The MAC 700 Profile is packaged in either a cardboard box or a two-unit flight case that is designed to protect the product during shipment. The following items are included:

- OSRAM HTI 700/D4/75 lamp (installed)
- 2 clamp attachment brackets
- 5 extra metal gobos and one extra rotating gobo retaining spring
- this user manual
- one 6.3 AT fuse (installed) for use with 200 - 250 V AC power
- one 15 AT fuse for use with 100 -130 V AC power

Using for the first time

Before applying power to the fixture,

- carefully review the safety information on page 5,
- check that the fuse in the fuseholder between the main on/off switch and the power cable matches the local AC power voltage as described in “Power supply and main fuse” on page 7.
- install a cord cap (mains plug) on the power cable as described in “Power connection” on page 7
- unlock the tilt lock as described on page 24.

When powered up, check lamp alignment as described on page 9.

AC power

WARNING! For protection from electric shock, the fixture must be grounded (earthed). The AC mains supply must be fitted with a fuse or circuit breaker and ground-fault (earth-fault) protection.

Important! Check that the correct fuse is installed before applying power.

Power supply and main fuse

The MAC 700 Profile features an auto-sensing switch-mode power supply that automatically adapts to 100-130 V and 200-250 V AC mains supplies. However, a suitable main fuse must be installed to match the local AC mains supply. The MAC 700 Profile is supplied with two main fuses:

- a 6.3 AT fuse (installed) for use with AC supplies of 200 - 250 volts
- a 15 AT fuse (packed with user manual) for use with AC supplies of 100 - 130 volts

To install the correct fuse:

1. Disconnect the fixture from AC power.
2. Remove the main fuse holder, which is located beneath the power switch.
3. For operation on 200 - 250 VAC supplies, install the 6.3 A fuse. For operation on 100 - 130 VAC supplies, install the 15 A fuse.

Power connection

Important! Connect the MAC 700 Profile directly to AC power. Do not connect it to a dimmer system; doing so may damage the fixture.

You may need to install a cord cap (mains plug) that fits your supply on the power cable. A grounding-type (earthed) plug must be installed following the manufacturer's instructions. Table 1 shows some possible pin identification schemes; if the pins are not clearly identified, or if you have any doubts about proper installation, consult a qualified electrician.

To apply power, first verify that the head tilt locks are released and then set the power switch on the base to the "I" position.

Wire Color	Pin	Symbol	Screw (US)
brown	live	L	yellow or brass
blue	neutral	N	silver
yellow/green	ground (earth)		green

Table 1: Cord cap connections

Lamp

About the discharge lamp

The MAC 700 Profile is designed for use with an OSRAM HTI 700 W/D4/75 lamp. This highly efficient double-ended short-arc source provides a color temperature of 7500 K, a color rendering index greater than 85, an average service life of 750 hours and hot restrike.

Note that lamp power is automatically reduced to 400 W after 10 seconds when the fixture is blacked out with the dimmer. This enhances lamp life. The lamp returns to 700W as soon as the dimmer is opened.

Warning! *Installing any other lamp may create a safety hazard or damage the fixture!*

To reduce the risk of explosion, replace the lamp when it reaches the limit of its average service life, i.e. when usage reaches 750 hours. *Never* exceed the lamp's average service life by more than 10%. To read lamp hours from the control panel, please refer to "Readouts" on page 13. Replace the lamp immediately if it is deformed or in any way defective.

For maximum service life, avoid dousing the lamp before it has warmed up for at least 5 minutes.

Lamp replacement

Important! *Do not touch the quartz bulb with bare fingers. Wear safety glasses and gloves when handling lamps.*

Replacement lamps are available from your Martin dealer (P/N 97010212).

The clear quartz bulb must be clean and free of any oils from your fingers. Clean the lamp with an alcohol wipe and polish it with a dry cloth, particularly if you accidentally touch the bulb.

To replace the lamp

1. Disconnect the fixture from power and allow it to cool for at least 45 minutes or until the lamp access plate is cool enough to touch. Lock the head right-side up.
2. Release the 4 quarter-turn fasteners marked with arrows on the lamp access plate, as shown in Figure 1. Pull the lamp assembly straight back as far as it goes and let it rest in place.
3. Push down the retention spring on the right end of the socket and push out the pin. You can use a screwdriver to gently pry the lamp out of the socket as shown in Figure 2. Remove the lamp.

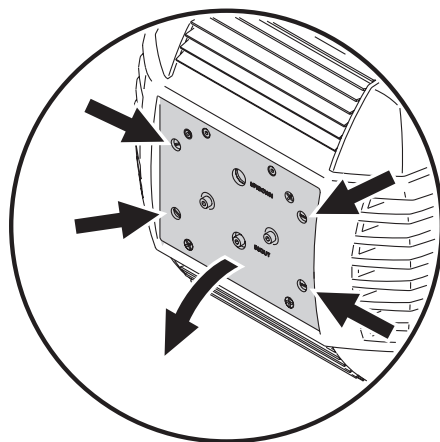

Figure 1: Lamp access

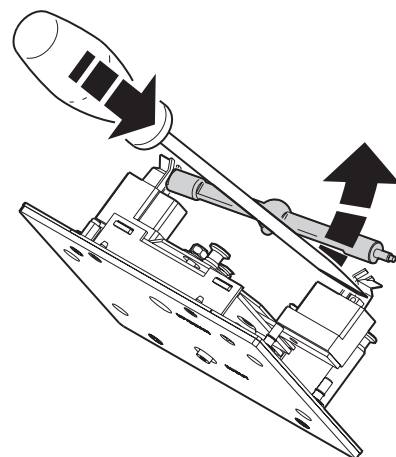

Figure 2: Lamp removal

- With the nipple on the replacement lamp facing towards the back as shown in Figure 3, insert the left pin into the socket. Push down on the right-hand spring and snap the pin into place.

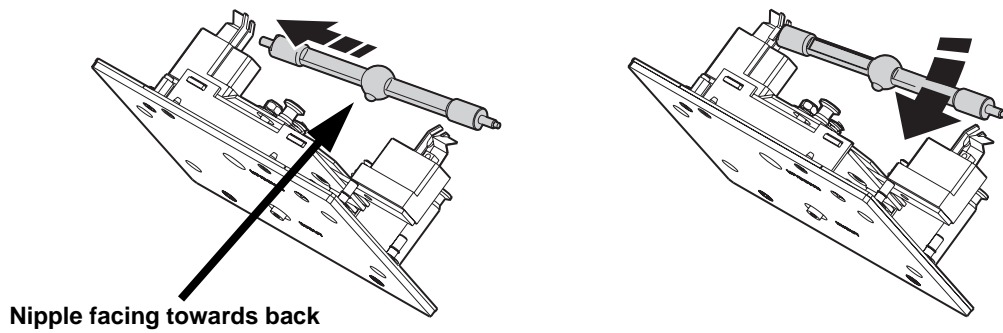

Figure 3: Lamp insertion

- Make sure that the terminals on the lamp sit below the V-section in the lampholder clips and not in the V-section itself, as shown in Figure 4.

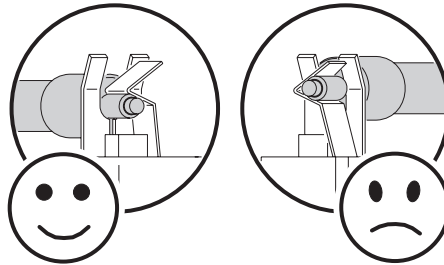

Figure 4: Lamp terminals

- Lift the lamp assembly so that lamp is level with the center of the reflector. Push the assembly straight in until it seats, making sure the lamp passes through the reflector opening.
- Push and turn the 4 fasteners a quarter turn or so clockwise to close the lamp access panel.
- After installing a new lamp, reset the lamp hour and lamp strike counters. See "Time" on page 13.

To align the lamp

Important! *Align the lamp carefully. An excessive hot-spot will damage optical components.*

- Apply power and allow the MAC 700 Profile to reset. Using either a controller or the control menu, strike the lamp and project an open white beam on a flat surface.
- See Figure 5. Center the hot spot vertically using the top Allen-head adjustment screw (A) in the center of the rear plate. Center the hot spot horizontally using the side-to-side adjustment screws (C).
- If there is an excessive hot spot, turn the bottom adjustment screw (B) counterclockwise until the light is evenly distributed. If the light is brighter around the edge than it is in the center, or if light output is low, turn the bottom adjustment screw (B) clockwise until the light is bright and evenly distributed.

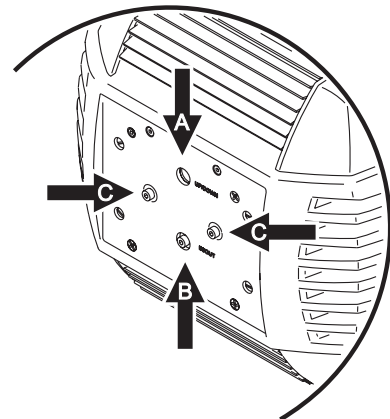

Figure 5: Lamp adjustment screws

DMX data link

Important! Never connect more than 1 data input and 1 data output.

The MAC 700 Profile has both 3-pin and 5-pin XLR sockets for DMX input and output. The pin-out on all sockets is pin 1 to shield, pin 2 to cold (-), and pin 3 to hot (+). There is no connection to pins 4 and 5.

The sockets are wired in parallel: both inputs connect to both outputs. *To avoid damage to the fixture, never use more than one input and one output socket!*

Tips for reliable data transmission

- Use shielded twisted-pair cable designed for RS-485 devices: standard microphone cable cannot transmit control data reliably over long runs. 24 AWG cable is suitable for runs up to 300 meters (1000 ft). Heavier gauge cable and/or an amplifier is recommended for longer runs.
- Never use both outputs to split the link. To split the serial link into branches use a splitter such as the Martin 4-Channel Opto-Isolated RS-485 Splitter/Amplifier.
- Do not overload the link. Up to 32 devices may be connected on a serial link.
- Terminate the link by installing a termination plug in the output socket of the last fixture. The termination plug, which is a male XLR plug with a 120 Ohm, 0.25 Watt resistor soldered between pins 2 and 3, “soaks up” the control signal so it does not reflect and cause interference. If a splitter is used, terminate each branch of the link.
- Some older fixtures have reversed polarity data sockets (pin 2 hot and pin 3 cold). Polarity is normally labelled on devices and described in user manuals. *Use a phase-reversing cable between the MAC 700 Profile and any device with reversed polarity.*

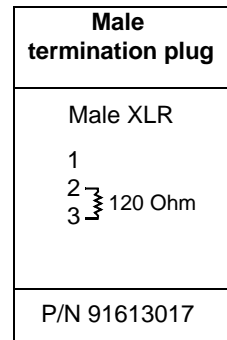
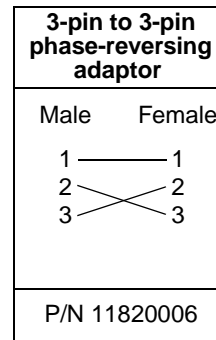

To connect the data link

1. Connect the DMX data output from the controller to the MAC 700 Profile’s 3-pin or 5-pin input (male) socket.
2. Using the sockets that match your data cable, connect the output of the fixture closest to the controller to the input of the next fixture.
3. Insert a male 120 Ohm XLR termination plug in the 3-pin or 5-pin output of the last fixture on the link.

Rigging

The MAC 700 Profile can be placed on stage or clamped to a truss in any orientation. The mounting points allow the clamp brackets to be fastened parallel or perpendicular to the front as shown Figure 6.

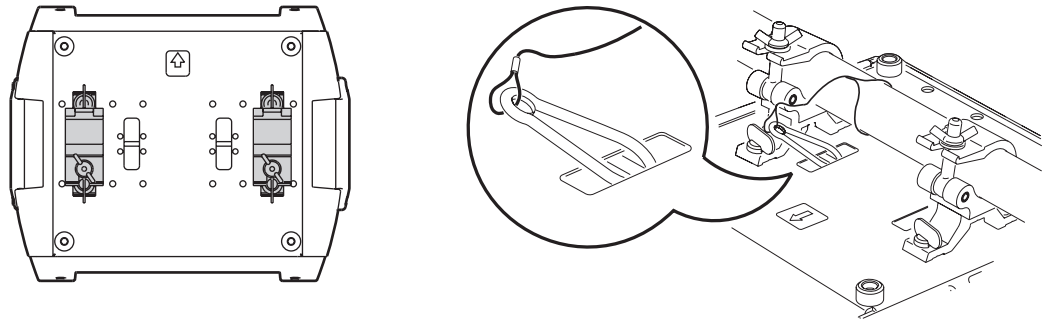

Figure 6: Clamp bracket positions and safety wire attachment point

Warning! Always use 2 clamps to rig the fixture. Lock each clamp with both 1/4-turn fasteners. The fasteners are locked only when turned fully clockwise.

Warning! Attach an approved safety cable to the attachment point labelled "SAFETY WIRE" in the base. Never use the carrying handles for secondary attachment.

To clamp the fixture on a truss

1. Check that the rigging clamps are undamaged and can bear at least 10 times the weight of the fixture. Check that the structure can bear at least 10 times the weight of all installed fixtures, clamps, cables, auxiliary equipment, etc.
2. Bolt each clamp securely to a clamp bracket with an M12 bolt (minimum grade 8.8) and lock nut.
3. Align a clamp with 2 mounting points in the base. Insert the fasteners into the base and turn both levers a full 1/4-turn clockwise to lock. Install the second clamp.
4. Block access under the work area. Working from a stable platform, hang the fixture on the truss with the arrow towards the area to be illuminated. Tighten the rigging clamps.
5. Install a safety wire that can bear at least 10 times the weight of the fixture. The attachment point is designed to fit a carabiner clamp.
6. Check that the tilt lock is released. Verify that there are no combustible materials or surfaces to be illuminated within 1.2 meters (42 inches) of the fixture, and that there are no flammable materials nearby.
7. Check that there is no possibility of heads or yokes colliding with other fixtures.

Control panel

You can set the MAC 700 Profile's DMX address, configure individual fixture settings (personality), read out data, and execute service utilities from the fixture's control panel. Settings can also be changed remotely via the DMX link with the Martin MP-2 uploader.

See also the control menu overview starting on page 35 for a complete list of the menus and commands available in the control panel.

Menu navigation

The DMX address and any status messages (see page 41) are displayed on the control panel when the MAC 700 Profile is powered on. To enter the menu, press [Menu]. Press [Up] and [Down] to move within the menu. To select a function or submenu, press [Enter]. To escape a function or menu, press [Menu].

Note: [Enter] must be pressed and held for a few seconds to enter the Utilities menu.

DMX address and protocol

The DMX address, also known as the start channel, is the first channel used to receive instructions from the controller. For independent control, each fixture must be assigned its own control channels. Two MAC 700 Profiles may share the same address, however, if identical behavior is desired. Address sharing can be useful for diagnostic purposes and symmetric control, particularly when combined with the inverse pan and tilt options.

Depending on the selected DMX mode, the MAC 700 Profile requires 23 or 31 DMX channels. The basic mode uses 23 channels and provides coarse control of all effects plus fine control of gobo rotation, pan, and tilt. The extended mode uses 31 channels and provides the basic mode features plus fine control of the dimmer, color wheel, CMY color mixing, iris, focus, and zoom.

DMX addressing is limited to channels 1-490 (in basic mode) and 1-482 (in extended mode). This makes it impossible to set the DMX address so high that you are left without enough control channels for the fixture.

To set DMX address and protocol

1. Press [Menu] to enter the main menu.
2. Press [Up] until **ADDR** is displayed. Press [Enter]. To snap to channel 1, press [Enter] and [Up]. Scroll to the desired channel and press [Enter].
3. Select **PSET** from the main menu and press [Enter]. Select **16BT** for basic mode, or **16EX** for extended mode. Press [Enter].

Tailoring performance

MOVEMENT

The MAC 700 Profile provides several options for optimizing movement for different applications.

- The protocol setting (**PSET**) setting selects the basic (**16BT**) or extended (**16EX**) control mode. Extended mode provides finer position control of the dimmer, color wheel, CMY color mixing, iris, focus lens, and zoom lens than the basic mode.
- The pan and tilt invert (**PATI**) menu swaps and/or inverts pan and tilt.
- The pan/tilt speed (**PTSP**) menu provides 3 settings: **FAST**, **NORM**, and **SLOW**. **NORM** is best for most applications. **FAST** provides better performance in applications where speed is most important. **SLOW** provides the smoothest movement and is best in long-throw applications with slow movements through narrow angles.
- The studio mode (**STUD**) setting optimizes all effects besides pan and tilt for quietness or speed.

- The shortcuts (*PERS*→*SCUT*) setting determines whether the gobo and color wheels take the shortest path between two positions, crossing the open position if necessary, or always avoid the open position.

DIMMER

The dimmer curve setting (*PERS*→*DIKU*) provides two options for dimmer behavior. Select *DIM 1* to simulate tungsten dimming or *DIM 2* for more linear dimming.

DISPLAY

The display intensity (*PERS*→*DIINT*) setting controls display brightness. Select *AUTO* for automatic display or manually set the intensity to a level from *10* to *100*.

The display on/off setting (*PERS*→*DIISP*) determines whether the display remains on (*ON*), remains on for 2 minutes after the last key press (*2 MN*), or for 10 minutes after the last key press (*10MN*).

To flip the display, press [Up] and [Down] simultaneously.

LAMP

There are two settings that modify lamp control: Automatic Lamp On (*PERS*→*ALON*) and DMX Lamp Off (*PERS*→*DLDF*).

When *ALON* is *OFF*, the lamp remains off until a “lamp on” command is received. When *ALON* is *ON*, the lamp strikes automatically after the fixture is powered on. When *ALON* is set to *DMX*, the lamp strikes automatically when the fixture receives DMX data, and it douses 15 minutes after DMX data is lost.

When *ALON* is set to either *ON* or *DMX*, the automatic lamp strike timing is staggered to prevent all lamps from striking at once. The delay is determined by the fixture address.

The DMX Lamp Off (*DLDF*) setting allows you to enable (*ON*) or disable (*OFF*) the DMX command that switches off the lamp. The special combination of DMX values listed on page 29 allows you to execute the lamp-off command even when disabled.

DMX RESET

The DMX reset (*PERS*→*DRRES*) setting controls the behavior of the reset command. When set to *ON*, the command is fully enabled. When set to *OFF*, the command is disabled to prevent accidental resets. When set to *5SEC*, the command must be sent for five seconds. The special combination of DMX values listed on page 29 allows you to execute a reset even when the command is disabled.

CMY AND IRIS BLACKOUT

The CMY blackout (*PERS*→*CMY B*) and iris blackout (*PERS*→*IRI B*) settings enhance blackout effectiveness. When set to *ON*, the CMY flags and iris deploy 3 seconds after dimmer blackout. These absorb any light that may escape past the dimmer.

The CMY flags and iris take a fraction of a second longer to open than the dimmer blades, however, so setting CMY and iris blackout to *OFF* (the default setting) allows the fixture to snap open more rapidly after a blackout.

CUSTOM SETTINGS

The custom configuration function *DFSE*→*CUS 1- CUS 3* allows you to save and recall three sets of fixture settings. The savable settings are DMX mode, pan/tilt speed, pan/tilt inverse and swap, DMX lamp off and reset, display settings, shortcuts, studio mode, automatic lamp on, effects feedback, tracking algorithm, and tracking samples.

Readouts

TIME

INFO→*TIME* provides readouts of fixture hours (*HRS*), lamp hours (*L HR*), and lamp strikes (*L ST*). Under each item is a resettable (*RSET*) increment counter and a non-resettable (*TOTL*) counter for total accumulated hours/strikes since fabrication. To reset an increment counter, display it and then press [Up] until it reads *0*. (This may also be done remotely using the MP-2 Uploader.)

TEMPERATURE

INFO→*TEMP* provides temperature readouts for the head, lamp, PCB and power supply in Celsius and Fahrenheit.

FIRMWARE VERSION

INFO→*VER* displays the version number of the installed firmware. The firmware version is also displayed briefly at startup.

DMX

The DMX log (*DMXL*) menu provides useful information for troubleshooting control problems.

RATE displays the DMX refresh rate in packets per second. Values lower than 10 or higher than 44 may result in erratic performance, especially when using tracking control.

QUAL displays the quality of the received DMX data as a percentage of packets received. Values much below 100 indicate interference, poor connections, or other problems with the serial data link that are the most common cause of control problems.

STCO displays the DMX start code. Packets with a start code other than 0 may cause irregular performance.

The remaining options under *DMXL* display the DMX values received on each channel. If the fixture does not behave as expected, reading the DMX values can help you troubleshoot the problem.

Service messages

The Service LED on the control panel lights under conditions that require fixture service, and there is a message describing the service required. To display the message, select *SMSG* in the main menu. This item is available only when the LED is lit. There are two service messages.

REPLACE LAMP is displayed when the lamp counter exceeds 750 hours, which is the rated average life for the lamp.

FIXTURE OVERHEATING is displayed when the head temperature exceeds 85° C (185° F). Overheating is probably due to dirty air filters, fans, or air vents; incorrect power supply settings, or a defective fan.

Manual control

The manual control menu (*MAN*) provides commands for resetting the fixture (*RST*), striking the lamp (*LON*), and dousing the lamp (*LOFF*). It also permits you to position and move individual effects.

Service utilities

Important! *[Enter]* must be held for several seconds to access the utilities menu.

TEST SEQUENCES

TSEQ provides a general test of all effects that can be run without a controller. *UTIL*→*PCBT* provides routines for circuit board testing that are for service use only.

FEEDBACK TOGGLES

An on-the-fly position correction system monitors the gobo and color wheels, rotating gobos, and the animation wheel. If a position error is detected, the shutter closes while the effect resets. This feature can be disabled by turning effects feedback (*UTIL*→*EFFB*) off.

The automatic pan/tilt position correction system may be temporarily turned off under *UTIL*→*FEBR*. The off setting, however, is not saved and the system will be re-enabled the next time the fixture starts. If the system cannot correct the pan/tilt position within 10 seconds, feedback is automatically disabled.

ADJUSTMENT

The adjustment menu (*UTIL*→*ADJ*) provides manual control for making mechanical adjustments. See page 39.

CALIBRATION

The calibration menu (*UTIL*→*CAL*) provides utilities to define offsets in software that are relative to the mechanical reset or home positions. This allows you to fine tune optical alignment and achieve uniform performance between fixtures. Dimmer and zoom are calibrated to defined points. The other effects are calibrated relative to an arbitrary reference fixture.

All offsets can be set to *128* (the middle of their adjustment range) with the default offset command: select *UTIL*→*CAL*→*DOF*→*SURE* then press [Enter].

To calibrate effects

1. Apply power but do not strike the lamp until zoom has been calibrated.
2. To calibrate zoom, first remove the bottom head cover. Select *UTIL*→*CAL*→*ZDOF* and press [Enter]. Adjust the offset until the face of the zoom lens plate is flush with the back edge of the focus plate. Press [Enter] to save the setting. Replace the bottom head cover.
3. Pan calibration is most useful when multiple fixtures are stacked vertically. To calibrate, set zoom, focus, iris, and tilt position for easy one-over-the-other comparison and set each fixture to the same pan DMX value. Select one fixture to be the reference fixture. On the other fixtures, select *UTIL*→*CAL*→*P OF* and press [Enter]. Adjust the offset as necessary to align the beam with the reference beam. Press [Enter] to save the setting.
4. Tilt calibration is most useful when multiple fixtures are arranged horizontally. To calibrate, set zoom, focus, iris, and pan position for easy side-by-side comparison and set each fixture to the same tilt DMX value. Select one fixture to be the reference fixture. On the other fixtures, select *UTIL*→*CAL*→*T OF* and press [Enter]. Adjust the offset as necessary to align the beam with the reference beam. Press [Enter] to save the setting.
5. To calibrate the dimmer, set the iris to fully closed and set focus to 1m in the *UTIL*→*ADJ* menu. Select *UTIL*→*CAL*→*D OF* and press [Enter]. Hold a piece of paper over the lens. Set the offset to zero and then increase it until a clearly defined M shape with minimal light spill is projected onto the paper. Press [Enter] to save the setting and remove the paper.
6. To calibrate color mixing flags (cyan, magenta and yellow), project white beams with no dimming and position them for easy comparison. On each fixture, *including the reference*, select *UTIL*→*CAL*→*C OF* and press [Enter]. This adds a defined amount of cyan. Select one fixture to be the reference. Adjust the offsets on the other fixtures to match the reference color. Press [Enter] to save the setting. Repeat for *M OF* (magenta) and *Y OF* (yellow).
7. Focus calibration is useful when two or more fixtures are the same distance from a projection surface. To calibrate focus, set up all fixtures with the same focus, zoom, dimming, iris, and gobo values. Select a focused fixture to be the reference. On the other fixtures, select *UTIL*→*CAL*→*FDOF* and press [Enter]. Adjust the offset to focus the image. Press [Enter] to save the setting.

FANS

The cooling fans can be set to either full speed or thermostatically regulated operation via *UTIL*→*FANS*. In lower ambient temperature environments, regulated operation is recommended if reduced noise levels are desired. Service life of lamps, fans, etc. is maximized if fans are set to full speed.

SOFTWARE UPLOAD

The upload mode command (*UTIL*→*UPL D*) prepares the fixture for a software update. This command is not normally necessary, as upload mode is engaged automatically by the uploader.

Effects

This section describes the functions programmed in the MAC 700 Profile DMX protocols.

The MAC 700 Profile has two DMX operating modes, 16-bit basic and 16-bit extended. The extended mode requires eight more DMX channels than the basic mode and provides all features of the basic mode plus fine control of the dimmer, cyan, magenta, yellow, color wheel, iris, zoom, and focus.

Where fine control is available, the main control channel sets the first 8 bits (the most significant byte or MSB), and the fine channels set the second 8 bits (the least significant byte or LSB) of the 16-bit control byte. In other words, the fine channel works within the position set by the coarse channel.

See page 29 for the complete DMX protocol.

Lamp power

LAMP-ON

The lamp-on command on channel 1 strikes the lamp if it is off. If the lamp is on, this command has no effect.

Note: A peak of electric current that can be many times the operating current is drawn for an instant when striking a discharge lamp. Striking many lamps at once may cause a voltage drop large enough to prevent lamps from striking or draw enough current to trip circuit breakers. If sending lamp-on commands to multiple fixtures, program a sequence that strikes lamps one at a time at 5 second intervals.

LAMP-OFF

The lamp can be doused from the controller with the lamp-off command on channel 1. The command must be sent for 5 seconds.

If the lamp-off command is disabled in the control menu (*PERS*→*ILDF*→*OFF*), the lamp-off command can still be selected on channel 1 if the following effects are also selected:

- color wheel: slot 1 – DMX 189 - 193 on channel 6 (basic mode) or 10 (extended)
- prism: on, no rotation – DMX 80 - 89 on channel 14 (basic) or 19 (extended)
- gobo wheel 1 (rotating gobos): open – DMX 0 - 11 on channel 7 (basic) or 12 (extended)
- gobo wheel 2 (static gobos): open – DMX 0 or 194 - 202 on channel 10 (basic) or 15 (extended)

400 W AND 700 W LAMP POWER MODES

If full light output is not required, the lamp can be switched to 400 W mode by sending a DMX value from 238 to 242 on channel 1. Running in 400 W mode will significantly increase lamp life.

If the shutter is closed for longer than 10 seconds while the lamp is in 700 W mode, lamp power is automatically switched to 400 W. When the shutter is opened again, the lamp returns to 700 W mode.

Fixture reset

If an effect loses its indexing and fails to move to programmed positions, the fixture can be reset from the controller by sending the “Reset” command on channel 1.

If DMX reset is disabled in the control menu (*PERS*→*JRES*→*OFF*), the reset command can only be executed if the conditions listed under “Lamp-off” are met. If it is set to *5SEC*, the reset command must be sent for 5 seconds before it is executed.

Dimming and strobe

The mechanical dimmer/shutter system provides smooth, high-resolution 100 percent dimming, instant open and blackout, random and variable strobe effects up to 10 Hz, and random and variable pulses in which the dimmer snaps open and slowly dims or snaps closed and slowly opens.

Fine control of the dimmer is available on channel 3 in extended mode.

Cyan, Magenta and Yellow

Cyan, magenta and yellow can be added on channels 3, 4 and 5 (4, 6 and 8 in extended mode). Fine control is available on channels 5, 7 and 9 in extended mode.

Color wheel

The color wheel has 8 color filters that can scroll continuously, allowing split colors, or in full-color steps. The DMX protocol provides commands for random and continuous color scrolling at different speeds.

Fine control of the color wheel is available on channel 11 in extended mode.

Rotating gobos

The rotating gobo wheel (gobo wheel 1) has six gobos that can be selected, indexed (positioned at a programmed angle), rotated continuously, and shaken (bounced). The gobo wheel can also be scrolled continuously. These features are controlled on channel 7 (12 in extended mode). Index angle or rotation speed is set on channel 8 (13 in extended mode), with fine control available on channel 9 (14 in extended mode).

Static gobos

The static gobo wheel (gobo wheel 2) has nine static gobos and can be scrolled continuously (allowing split gobo effects) or in full-gobo steps using channel 10 (15 in extended mode). Random gobo scrolling and continuous gobo wheel rotation can also be set at different speeds.

Gobo/color macros

Channel 11 (16 in extended mode) provides pre-programmed variable-speed macros that use different combinations of color and gobos.

Gobo animation

The gobo animation system is designed to create animated effects such as rising flames or windswept clouds when combined with other gobos.

Channel 12 (17 in extended mode) sets the animation wheel's rotation mode (indexed or continuous), and start position.

Channel 13 (18 in extended mode) sets the wheel's:

- index angle if indexed rotation is selected on channel 12 (17 in extended mode)
- rotation speed and direction if continuous rotation is selected on channel 12 (17 in extended mode).

Prism and iris

On channel 14 (19 in extended mode), the prism can be added and rotated clockwise and counterclockwise at varying speeds.

Channel 15 (20 in extended mode) controls the diameter of the iris opening and provides variable speed pulsing effects. Fine control of the iris is provided on channel 21 in extended mode.

Focus and zoom

The focus lens focusses the beam from approximately 2 meters (6.5 feet) to infinity. The separate zoom lens varies the focused beam angle from 14° to 30°. Fine control of focus is available on channel 23 in extended mode. Fine control of zoom is available on channel 25 in extended mode.

Diffuser

A diffuser glass is fitted to give an even light beam at very low light levels. The diffuser can be removed to give approximately 10% higher light output (see “Diffuser” on page 23) for details of removal/installation.

Pan and tilt

Pan and tilt are controlled on channels 18 to 22 (26 to 30 in extended mode). Coarse and fine control are available in both basic and extended modes.

Pan/tilt speed and effects speed channels

TRACKING VERSUS VECTOR CONTROL

Important! Effect movement may be rough and unpredictable if controller fade times are combined with vector speed values.

The speed channels provide two methods for controlling speed that are known as “tracking” and “vector”.

With tracking control, the speed at which effects move is determined by a cross-fade time programmed on the controller. With this method, the controller divides a movement into tiny steps that the fixture “tracks”. Tracking control is enabled via the speed channel for the effect concerned.

With vector control, speed is set with a DMX value on the speed channel. This provides a way to control speed on controllers without cross-faders. Vector control can also provide smoother movement, particularly at slow speeds, with controllers that send slow or irregular tracking updates. When using vector control, the controller’s cross-fade time, if available, must be set to 0.

BLACKOUT

When “blackout while moving” is selected on a speed channel, the shutter closes when an effect moves to make the transition invisible. The shutter opens when the movement is complete. This function is available for pan and tilt on channel 30 (22 in basic mode) and for color, gobo selection, gobo movement and prism change on channel 31 (23 in basic mode).

PERSONALITY OVERRIDES

The pan/tilt speed channel provides tracking values that allow you to override the pan/tilt speed setting from the controller.

The effects speed channel provides values for overriding the shortcuts setting for the color and gobo wheels.

Optical configuration

Color wheel

The MAC 700 Profile features a color wheel with 8 interchangeable dichroic color filters and an open position. As standard the MAC 700 Profile is supplied with six color filters, a 3200 - 4100 K CTC filter and a 5500-2800 K CTC filter installed. The illustration shows the filter positions as seen from the lamp side. The DMX Protocol on page 29 gives details of color filter selection.

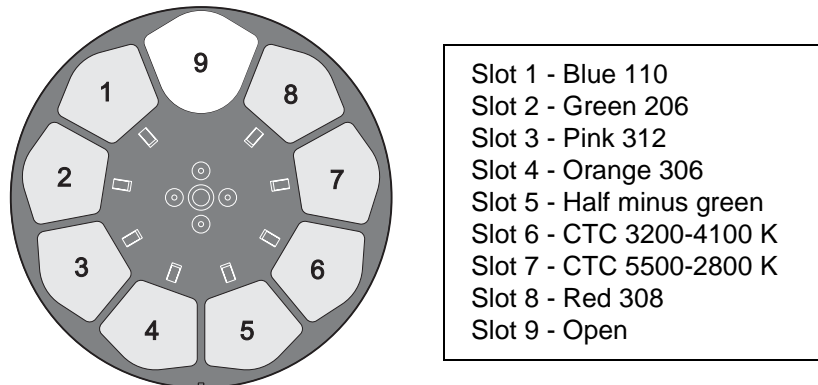

Figure 7: Filter positions, seen from lamp

To replace a color filter

Note: Wear cotton gloves while handling color filters and use only genuine Martin filters.

1. Disconnect the fixture from AC power and allow it to cool.
2. Lock the head in the upside-down position (the indication TOP on the back of the head must be upside down) and remove the bottom cover.
3. For best access, align the rotating gobo wheel so that the open position is above the color filter to be replaced (see arrow in Figure 8).
4. Turn the color wheel to access the desired filter position. Press the filter forwards slightly to release it and then grasp it by the edges and remove. If your fingers are too large, protect the glass with a piece of paper that has been folded several times and grasp the filter with needle nose pliers.
5. To insert a filter, slide it under the retention spring until it snaps into place.
6. Replace the cover and unlock the head before applying power.

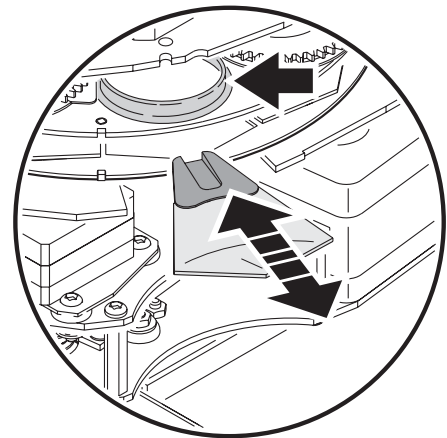

Figure 8: Filter replacement

Gobos

Gobo wheel 1 provides 6 rotating gobos; gobo wheel 2 provides 9 static gobos. The standard gobo configuration is shown in Figure 9. Five extra metal gobos are supplied with the fixture. All gobos are interchangeable with the following limitations:

- On wheel 1, the gobo retention spring works with gobos up to 3 mm in thickness. Thicker gobos can be glued to the holder with a UV adhesive or Loctite 330 Multibond with Activator.
- Gobo 3 on wheel 1 is glass, and must therefore be changed together with its holder. A spare gobo retention spring for use with a metal gobo is supplied with the product.
- The maximum thickness for gobos on wheel 2 is 1.1 mm (0.043 inches).

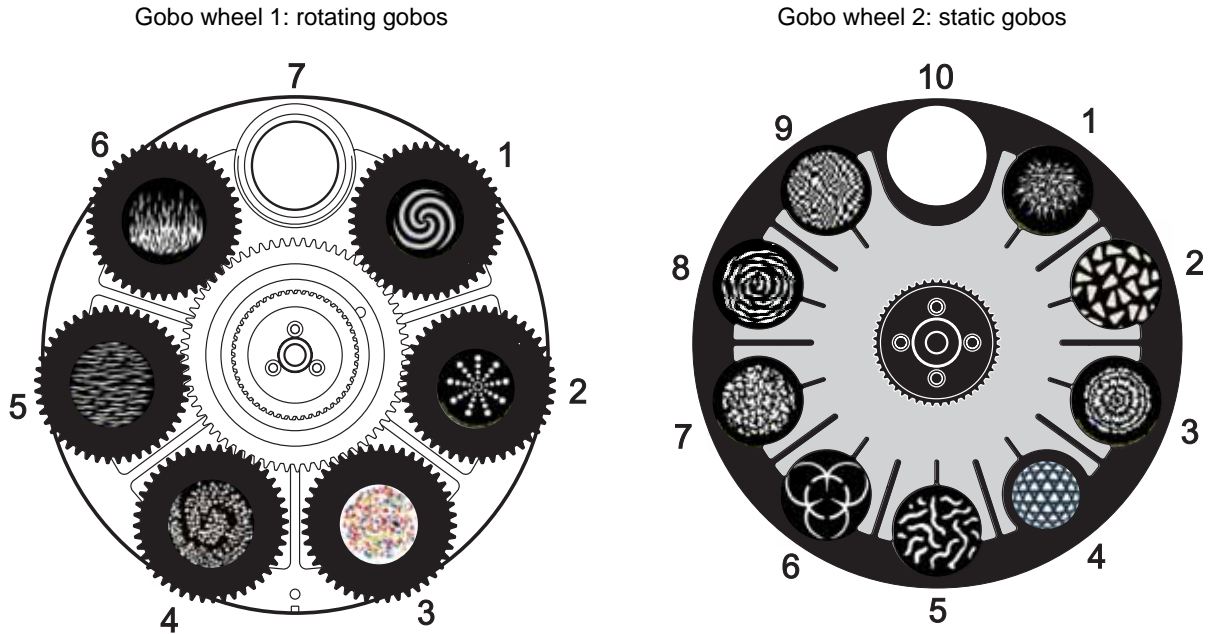

Figure 9: Gobo wheels as seen from front lens

CUSTOM GOBOS

Martin can provide many additional gobos for the MAC 700 Profile. Gobos are interchangeable between MAC 500, MAC 550 and MAC 700 fixtures. For more information, please visit the Martin web site at www.martin.com.

For optimum performance and gobo life, custom glass gobos should be made with the artwork reversed on the coated side and used with the coated side facing away from the lamp.

While glass gobos are generally the most durable, satisfactory results can be obtained at less expense with aluminum gobos. Custom stainless steel gobos can also be used, however they can warp, losing sharpness, in a matter of hours. The useful life will depend on the gobo pattern and the projection cycle. Consult your gobo supplier for more information.

For best results, custom gobos should meet the specifications listed on page 46.

GOBO ORIENTATION IN THE MAC 700 PROFILE

The orientations shown in Figure 10 are correct in most cases, but consult your Martin dealer or gobo supplier if you are in any doubt about the orientation of a specific gobo type.

Coated Glass Gobos

Focus is easiest to maintain if all coated gobos in a fixture are installed with their coatings as close as possible to the same plane of focus. The coated gobos in the MAC 700 Profile are factory-installed in this position. However, if there is an unusually high risk of heat damage on a custom coated gobo, the first priority is normally to ensure that more reflective sides face towards the lamp. If in doubt, install coated gobos with the more reflective side towards the lamp, or consult your Martin dealer or gobo supplier.

More reflective side towards lamp

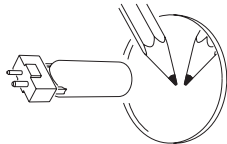

To minimize the risk of gobo overheating and damage, turn the more reflective side of a coated gobo towards the lamp.

Less reflective side away from lamp

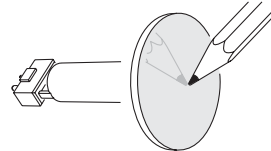

The less reflective side of a coated gobo will absorb less heat if it faces away from the lamp.

To determine which side of a gobo is coated, hold an object up to it. On the uncoated side, there is a space between the object and its reflection and the edge of the gobo can be seen when looking through the glass.

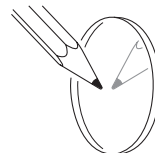

Uncoated side

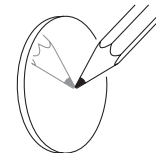

Coated side

Textured Glass Gobos

Textured side towards lamp

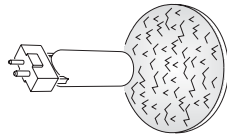

Smooth side away from lamp

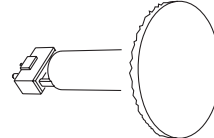

Textured glass gobos in the MAC 700 Profile sit most squarely in the gobo wheel with the textured side towards the lamp. If in doubt, consult your Martin dealer or gobo supplier.

Metal Gobos

Reflective side towards lamp

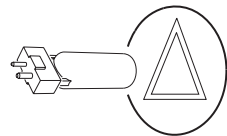

Black side away from lamp

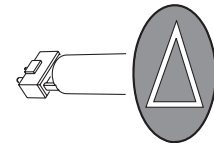
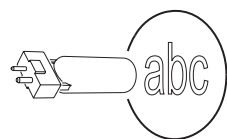

Image / text Gobos

True image towards lamp



Reversed image away from lamp

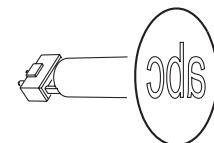

Figure 10. Correct gobo orientation

To replace rotating gobos

Important! The gobo can fall out if the spring is inserted backwards.

1. Disconnect the fixture from power and allow it to cool.
2. Position the head upside down and remove the bottom head cover. Turn the gobo wheel to the desired position. Grasp the holder by the teeth and pull the holder lightly towards the front lens to release the holder and remove it from the wheel.
3. With a small screwdriver or similar, unhook the end of the gobo spring furthest from the gobo and pull out the spring. Drop the gobo out of the holder.
4. Insert the new gobo in the holder with the side that faces towards the lamp facing upwards, towards the spring (see Figure 10 and Figure 11).
5. Insert the spring with the narrow end against the gobo, as shown in Figure 11. To identify the narrow end, press the spring flat: the narrow end is on the inside. Push the end of the spring in under the lip of the holder.
6. Verify that the gobo is seated flush against the holder. Press the spring as flat as possible against the back of the gobo.
7. Work the rim of the gobo holder under both clips and snap the gobo holder back into position on the gobo wheel. If necessary, a small screwdriver or similar tool may be used to pry the clips away from the wheel.
8. Replace the bottom cover and release the tilt lock before applying power.

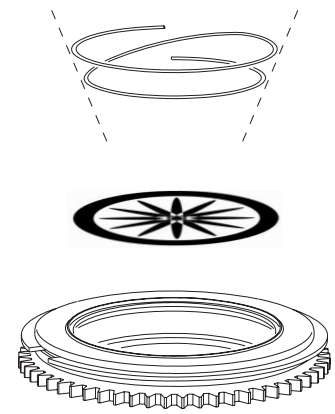

Figure 11: Rotating gobo holder

To replace static gobos

1. Disconnect the fixture from power and allow it to cool.
2. Remove the top head cover.
3. Turn the gobo wheel to the desired position. Press the gobo from the lamp side to release. Remove the gobo.
4. To insert a gobo, orient the gobo as shown in Figure 10 and place the edges under the retention spring. Verify that the gobo is centered in the opening.
5. Replace the top head cover and release the tilt lock before applying power.

Animation wheel

The MAC 700 Profile comes with the “Radial breakup” gobo animation wheel installed. Five additional stock patterns are available as accessories from Martin dealers.

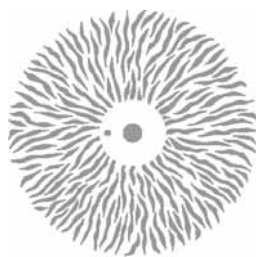

Radial breakup (included)
P/N 62325048



Spiral breakup (optional)
P/N 62325049



Linear breakup (optional)
P/N 62325050



Coarse tangential (optional)
P/N 62325051

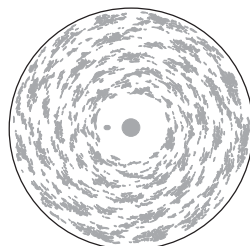

Cloud breakup (optional)
P/N 62325094



Elliptical breakup (optional)
P/N 62325095

Figure 12: MAC 700 Profile animation wheels

To replace the gobo animation wheel

Note: The replacement animation wheel can be inserted with the magnet in or out to suit your application. In fixed applications, install the wheel with the magnet forwards, away from the drive mechanism, for easier removal. In touring or similar applications where the fixture is frequently moved, install the animation wheel with the magnet in towards the drive mechanism for a more secure hold.

1. Disconnect the fixture from power and allow it to cool.
2. Remove the gobo module as described on page 24.
3. Stand the module on the work surface with the cooling fans to your left and the color wheel to your right.
4. Bring the animation wheel to the side of the module closest to you by turning the black belt on the right.
5. To avoid bending the animation wheel while removing, break the magnet's initial hold by prying the wheel off with a screwdriver inserted from the back. Once you have broken the hold, you can safely grasp the wheel by the edge and remove.
6. Orient the replacement wheel with the magnet in or out to suit your application (see note above this list). Place the wheel over the drive mechanism and align the hole in the wheel with the drive pin.
7. Reinstall the gobo module. Verify that the guide pins are correctly seated and that the module is securely locked.
8. Replace the head cover and release the tilt lock before applying power.

Diffuser

The MAC 700 Profile is supplied with a diffuser installed. This has the advantage of eliminating any pattern in the light beam that might be caused by the dimmer or CMY flags at very low output levels. However, the diffuser reduces total light output by approximately 10%. If slight patterning at very low output levels is not important, you may prefer to boost the maximum light output level by removing the diffuser.

To remove the diffuser

1. Disconnect the fixture from power and allow it to cool.
2. Remove the CMY module as described on page 26.

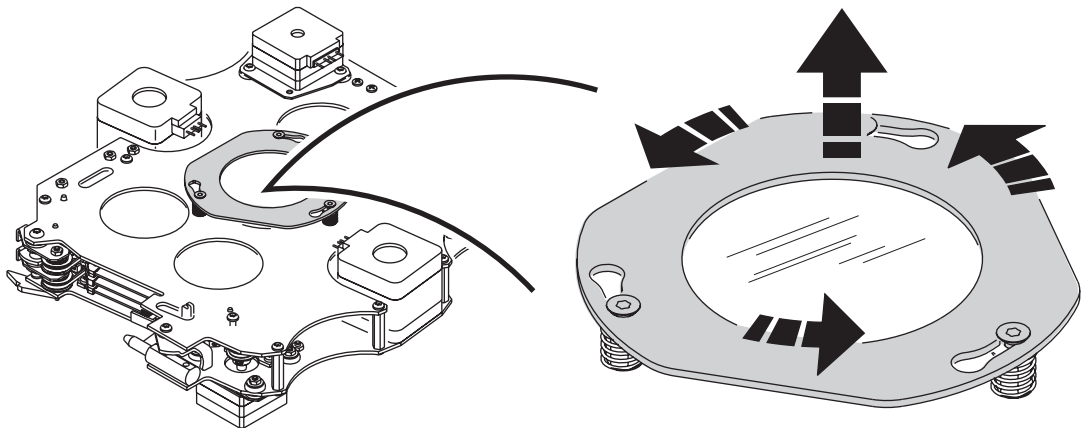

Figure 13: Removing the diffuser

3. The diffuser is held in a bayonet mount on the lens side of the CMY module. Push the diffuser's metal outer ring down slightly and turn counter-clockwise to release the diffuser from the three mounting points. Retain the diffuser for possible re-use.
4. Replace the CMY module and then replace the bottom cover. Release the head lock before applying power.
5. Reinstalling the diffuser is the reverse of the above procedure. Avoid contaminating the glass with grease from your fingers. If necessary, remove any traces of grease with 99% isopropyl alcohol and distilled water.

Routine maintenance

The MAC 700 Profile requires routine cleaning. The schedule depends heavily on the operating environment. It is essential to follow the cleaning guidelines given later in this section.

Refer any service operation that is not described here to a qualified Martin technician.

Important! *Excessive dust, smoke fluid, and particulate buildup degrades performance, causes overheating and will damage the fixture. Damage caused by inadequate maintenance is not covered by the warranty.*

Warning! *Disconnect the fixture from power and allow to cool for 45 minutes before removing any cover.*

Tilt lock

Important! *Release the tilt lock before operating the fixture.*

The tilt position of the head can be locked for transportation and service with the tilt lock. To lock or unlock the head, pull the lock out and turn it one-quarter turn in either direction.

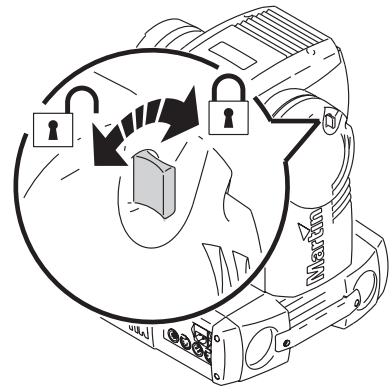

Figure 14: Tilt lock

Disassembly

To remove the gobo module

1. Disconnect the fixture from power and allow it to cool for 45 minutes.
2. Turn the four retaining screws in the top and bottom head covers one quarter-turn counter-clockwise to release the covers.
3. Remove the front lens by twisting one quarter-turn counter-clockwise.

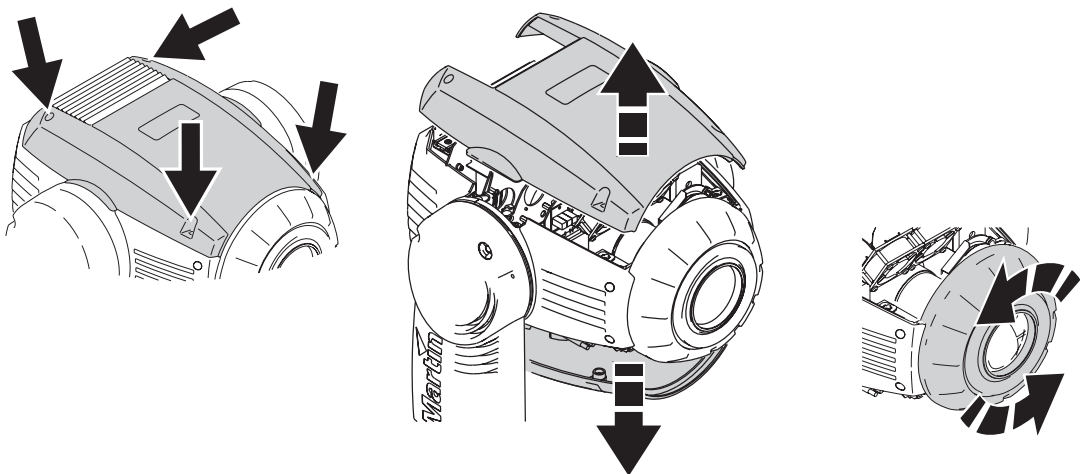

Figure 15: Releasing top and bottom covers and removing front lens

4. Position the head top side up so that you have access through the top. Holding the zoom lens by its base, slide it out to its limit at the front of the fixture as shown in Figure 16.

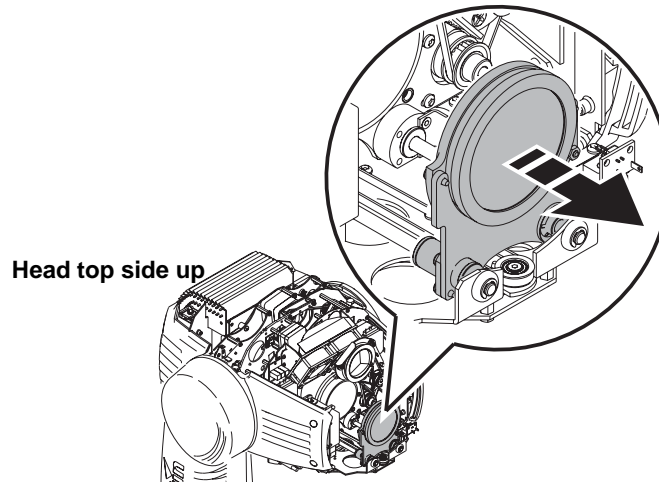

Figure 16: Moving the zoom lens forward

5. Flip the head upside-down. Move the focus lens to its forward limit by pulling on its belt as shown in Figure 17.

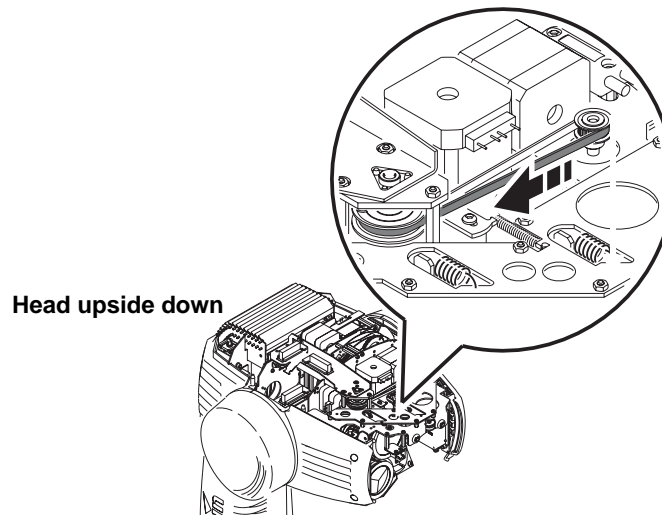

Figure 17: Moving the focus lens forward

6. Flip the head top side up again. To avoid bending the gobo animation wheel when you remove the module, move the wheel in towards the center of the module by inserting a finger and rotating the positioning belt idler pulley at the top of the module as shown in Figure 18.

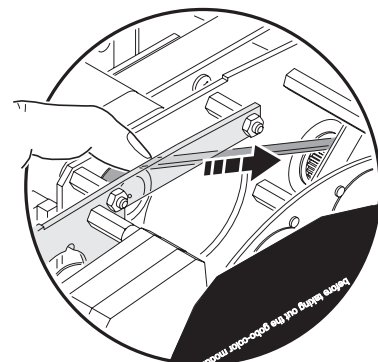

Figure 18: Retracting the gobo animation wheel

- Unlock the gobo module by pulling the levers on each side towards the center. Lift the module up 1 cm (0.5 in.) and release the levers. Lift the module straight up to remove from the head.

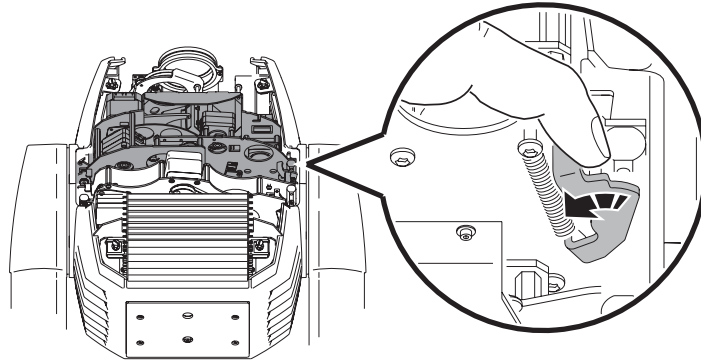

Figure 19: Gobo module locking levers

- When reinstalling the module, verify that the guide pins are correctly seated and that the module is securely locked.

To remove the CMY module

The CMY module can be removed for service and access to the lamp cooling fans and heat shield:

- Like the gobo module, the CMY module is also released by pulling on two levers. Lift the module straight up to remove from the head.
- When reinstalling, verify that the guide pins are correctly seated and that the module is securely locked.

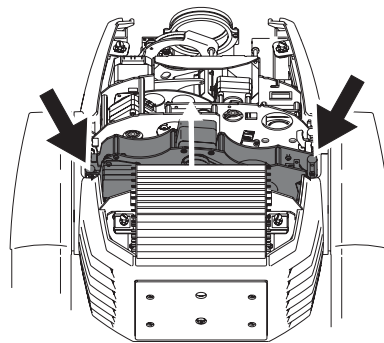

Figure 20: CMY module locking levers

Cleaning

Regular cleaning is very important for fixture life and performance. Buildup of dust, dirt, smoke particles, fog fluid residues, etc. degrades the fixture's light output and cooling ability.

Cleaning schedules for lighting fixtures vary greatly depending on the operating environment. It is therefore impossible to specify precise cleaning intervals for the MAC 700 Profile. Cooling fans suck in airborne dust and smoke particles, and in extreme cases fixtures may require cleaning after surprisingly few hours of operation. Environmental factors that may result in a need for frequent cleaning include:

- Use of smoke or fog machines.
- High airflow rates (near air conditioning vents, for example).
- Presence of cigarette smoke.
- Airborne dust (from stage effects, building structures and fittings or the natural environment at outdoor events, for example).

If one or more of these factors is present, inspect fixtures within their first 25 hours of operation to see whether cleaning is necessary. Check again at frequent intervals. This procedure will allow you to assess cleaning requirements in your particular situation. If in doubt, consult your Martin dealer about a suitable maintenance schedule.

Use care when cleaning optical components and work in a clean, well lit area. The coated surfaces are fragile and easily scratched. Do not use solvents that can damage plastic or painted surfaces.

To clean the fixture

1. Disconnect the fixture from power and allow the components to cool completely.
2. Remove the covers, front lens and gobo and CMY modules as described earlier.
3. Vacuum or gently blow away dust and loose particles with compressed air.
4. Carefully clean the optical components. Remove smoke and other residues with cotton swabs or unscented tissues moistened with isopropyl alcohol. A commercial glass cleaner may be used, but

residues must be removed with distilled water. Clean with a slow circular motion from center to edge. Dry with a clean, soft and lint-free cloth or compressed air. Remove stuck particles with an unscented tissue or cotton swab moistened with glass cleaner or distilled water. Do not rub the surface: lift the particles off with a soft repeated press.

5. Remove dust from the head fans and air vents with a soft brush, cotton swab, vacuum, or compressed air.
6. On each side of the head, remove the 2 screws that hold the side covers. Slide the covers forward to remove. Clean the air filters or replace them. If they are saturated with smoke fluid, etcetera, soak them in warm soapy water and blot dry. Position the filters on the side covers and reinstall. See Figure 21.
7. Reassemble the head.
8. Remove the screws from the side cover/grill on the front of the base (front is indicated by an arrow on the bottom). Remove the top cover from the front of the base. Lift the power supply / ballast module up and out to expose the base fans for inspection and cleaning.
9. Reinstall the power supply / ballast module and base cover.

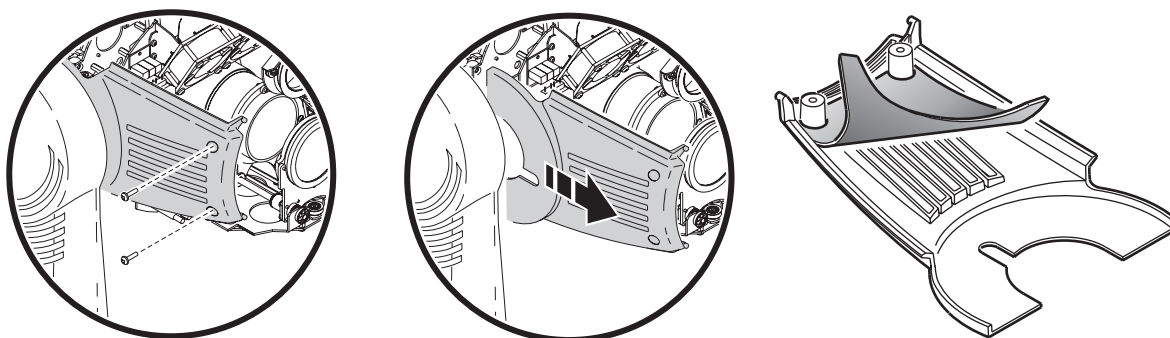

Figure 21: Air filter replacement

Lubrication

The MAC 700 Profile does not require lubrication under normal circumstances. The slides for the zoom and focus lens cars are lubricated with a long-lasting teflon-based grease that can be reapplied by a Martin service partner if necessary.

Replacing the lamp socket

The lamp holder used in the MAC 700 Profile eventually wears out due to the high voltages that pass through the contacts.

Wear begins to show up as discoloration at the contact surfaces. When this happens, resistance increases and the lamp becomes harder to strike. If this process is allowed to continue, the lamp is likely to fail prematurely.

Each time the lamp is replaced, inspect the lamp holder and have it replaced by a qualified technician as soon as there are signs of discoloration or pitting at the contact surfaces. Damage caused by failure to replace a worn and/or discolored lamp holder is not covered by the product warranty.

Software installation

Software updates are available from the Martin web site and can be installed via the data link with a Martin upload device.

The following are required in order to install software.

- The MAC 700 Profile update file, available for download from the User Support Area of the Martin web site (<http://www.martin.com>).
- The Martin Software Uploader program, version 5.0 or later, available for download from the User Support Area of the Martin web site.

- A Martin MP-2 Uploader connected to a Windows 95/98/ME/2000/XP PC, or one of the PC controller DMX interfaces supported by the Martin Software Uploader software.

To install software, normal method

Please refer to the MP-2 user manual and the Martin Software Uploader online help file.

To install software if all else fails (boot sector update)

Note: Use this procedure only if the firmware is totally corrupted, which is evident if the control panel does not respond when power is applied, or if the software update notes call for a boot sector update. In the event of a check sum error, repeat the normal upload procedure.

1. Disconnect the fixture from power.
2. Remove the side cover from the side of the base that has the control panel to expose the main PCB.
3. Locate the "BOOT" jumper on the main PCB (see page 43) and move the jumper cap to the "INIT" position.
4. Perform a boot mode upload as described in the uploader documentation.
5. When the upload is complete, disconnect the fixture from power and move the jumper back to the "DISABLE" position.
6. Reassemble the base.

MAC 700 Profile DMX protocol

16-bit Basic Mode	16-bit Extended Mode	DMX Value	Percent	Function
1	1	0 - 19	0 - 7	Shutter, strobe, reset, lamp on/off Shutter closed (lamp switches to 400 W mode after 10 seconds while shutter is closed)
		20 - 49	8 - 19	Shutter open
		50 - 72	20 - 28	Strobe, fast → slow
		73 - 79	29 - 30	Shutter open
		80 - 99	31 - 39	Opening pulse, fast → slow
		100 - 119	40 - 47	Closing pulse, fast → slow
		120 - 127	48 - 50	Shutter open
		128 - 147	51 - 57	Random strobe, fast
		148 - 167	58 - 65	Random strobe, medium
		168 - 187	66 - 73	Random strobe, slow
		188 - 190	74	Shutter open
		191 - 193	75	Random opening pulse, fast
		194 - 196	76	Random opening pulse, slow
		197 - 199	77	Random closing pulse, fast
		200 - 202	78 - 79	Random closing pulse, slow
		203 - 207	80 - 81	Shutter open
		208 - 217	82 - 85	Reset fixture* **
218 - 227	86 - 89	Shutter open		
228 - 237	90 - 93	Lamp on		
238 - 242	94 - 95	400 W mode (active until 700 W value is selected)		
243 - 247	96 - 97	700 W mode		
248 - 255	98 - 100	Lamp off*		
<div style="border: 1px solid black; padding: 5px;"> <p><i>*If disabled in the control menu, Reset fixture and Lamp off work only if the following effects are selected:</i></p> <ul style="list-style-type: none"> • <i>Color wheel to slot 1 – DMX value 17 on channel 6 (in basic mode) or 10 (extended mode)</i> • <i>Prism on, no rotation – DMX value 80-89 on channel 14 (basic) or 19 (extended)</i> • <i>Gobo wheel 1 open – DMX value 0 on channel 7 (basic) or 12 (extended)</i> • <i>Gobo wheel 2 open – DMX value 0 on channel 10 (basic) or 15 (extended)</i> <p><i>** A five-second delay for the Reset fixture command can be set in the control menu under DRES.</i></p> </div>				
2	2	0 - 255	0 - 100	Dimmer (MSB) Closed → open
-	3	0 - 255	0 - 100	Dimmer, fine (LSB)
3	4	0 - 255	0 - 100	Cyan (MSB) White → full cyan
		0	0	Cyan range in random CMY color when set on channel 11 (basic) or 16 (extended) Normal (full range)
		1 - 127	1 - 50	Minimum cyan setting (127 = full cyan)
		128 - 254	51 - 99	Maximum cyan setting (128 = no cyan)
255	100	Normal (full range)		
-	5	0 - 255	0 - 100	Cyan, fine (LSB)
4	6	0 - 255	0 - 100	Magenta (MSB) White → full magenta
		0	0	Magenta range in random CMY color when set on channel 11 (basic) or 16 (extended) Normal (full range)
		1 - 127	1 - 50	Minimum magenta setting (127 = full magenta)
		128 - 254	51 - 99	Maximum magenta setting (128 = no magenta)
255	100	Normal (full range)		
-	7	0 - 255	0 - 100	Magenta, fine (LSB)
5	8	0 - 255	0 - 100	Yellow (MSB) White → full yellow
		0	0	Yellow range in random CMY color when set on channel 11 (basic) or 16 (extended) Normal (full range)
		1 - 127	1 - 50	Minimum yellow setting (127 = full yellow)
		128 - 254	51 - 99	Maximum yellow setting (128 = no yellow)
255	100	Normal (full range)		
-	9	0 - 255	0 - 100	Yellow, fine (LSB)

16-bit Basic Mode	16-bit Extended Mode	DMX Value	Percent	Function
6	10			Color wheel (MSB)
				<i>Continuous scroll</i>
		0	0	Open
		1 - 16	1 - 6	Open → slot 1
		17	7	Slot 1 (Blue 110)
		18 - 33	8 - 12	Slot 1 → slot 2
		34	13	Slot 2 (Green 206 IAD)
		35 - 50	14 - 19	Slot 2 → slot 3
		51	20	Slot 3 (Pink 312)
		52 - 67	21 - 26	Slot 3 → slot 4
		68	27	Slot 4 (Orange 306M)
		69 - 84	28 - 32	Slot 4 → slot 5
		85	33	Slot 5 (Half minus green)
		86 - 101	34 - 39	Slot 5 → slot 6
		102	40	Slot 6 (CTC 3200 - 4100K)
		103 - 118	41 - 46	Slot 6 → slot 7
		119	47	Slot 7 (CTC 5500 - 2800K)
		120 - 135	48 - 52	Slot 7 → slot 8
		136	53	Slot 8 (Red 308)
		137 - 152	54 - 59	Slot 8 → open
		153	60	Open
				<i>Stepped scroll</i>
		154 - 158	61 - 62	Slot 8 (Red 308)
		159 - 163	63 - 64	Slot 7 (CTC 5500 - 2800K)
		164 - 168	65 - 66	Slot 6 (CTC 3200 - 4100K)
		169 - 173	67 - 68	Slot 5 (Half minus green)
		174 - 178	69 - 70	Slot 4 (Orange 306M)
179 - 183	71 - 72	Slot 3 (Pink 312)		
184 - 188	73 - 74	Slot 2 (Green 206 IAD)		
189 - 193	75 - 76	Slot 1 (Blue 110)		
194 - 198	77 - 78	Open		
		<i>Continuous rotation</i>		
199 - 219	79 - 86	CW, fast → slow		
220 - 240	87 - 94	CCW, slow → fast		
		<i>Random color</i>		
241 - 245	95 - 96	Fast		
246 - 250	97 - 98	Medium		
251 - 255	99 - 100	Slow		
-	11	0 - 255	0 - 100	Color Wheel: fine (LSB)

16-bit Basic Mode	16-bit Extended Mode	DMX Value	Percent	Function	
7	12	Gobo wheel 1 (rotating gobos): gobo selection, shake, rotation			
		<i>Indexed gobo: set angle on channel 8 (basic) or 13 (extended)</i>			
		0 - 11	0 - 4	Open	
		12 - 15	4 - 5	Gobo 1 (Spiral)	
		16 - 19	6 - 7	Gobo 2 (Radial Circles)	
		20 - 23	7 - 9	Gobo 3 (Fused Dichro Red/Yellow)	
		24 - 27	9 - 10	Gobo 4 (Milky Way)	
		28 - 31	11 - 12	Gobo 5 (Water)	
		32 - 35	12 - 13	Gobo 6 (Flames)	
		<i>Select gobo with continuous gobo rotation: set gobo rotation speed on channel 8 (basic) or 13 (extended)</i>			
		36 - 39	14 - 15	Gobo 1 (Spiral)	
		40 - 43	15 - 16	Gobo 2 (Radial Circles)	
		44 - 47	17 - 18	Gobo 3 (Fused Dichro Red/Yellow)	
		48 - 51	18 - 20	Gobo 4 (Milky Way)	
		52 - 55	20 - 21	Gobo 5 (Water)	
		56 - 59	22 - 23	Gobo 6 (Flames)	
		<i>Select gobo with indexed position and shake: set angle on channel 8 (basic) or 13 (extended)</i>			
		60 - 71	23 - 27	Gobo 1, slow → fast	
		72 - 83	28 - 32	Gobo 2, slow → fast	
		84 - 95	33 - 36	Gobo 3, slow → fast	
96 - 107	37 - 41	Gobo 4, slow → fast			
108 - 119	42 - 46	Gobo 5, slow → fast			
120 - 131	47 - 51	Gobo 6, slow → fast			
<i>Select gobo with continuous gobo rotation and shake: set gobo rotation speed on channel 8 (basic) or 13 (extended)</i>					
132 - 143	52 - 56	Gobo 6, slow → fast			
144 - 155	57 - 61	Gobo 5, slow → fast			
156 - 167	62 - 65	Gobo 4, slow → fast			
168 - 179	66 - 70	Gobo 3, slow → fast			
180 - 191	71 - 75	Gobo 2, slow → fast			
192 - 203	76 - 80	Gobo 1, slow → fast			
<i>Gobo wheel scroll with continuous gobo rotation: set gobo rotation speed on channel 8 (basic) or 13 (extended)</i>					
204 - 229	81 - 90	CW scroll, slow → fast			
230 - 255	91 - 100	CCW scroll, fast → slow			
8	13	Rotating gobo: indexing, speed (MSB)			
		<i>If indexed gobo is selected on channel 7 (basic) or 12 (extended)</i>			
		0 - 255	0 - 100	Rotating gobo indexing, 0 → 395°	
		<i>If continuous gobo rotation is selected on channel 7 (basic) or 12 (extended)</i>			
		0 - 2	0	No rotation	
3 - 127	1 - 50	CW, slow → fast			
128 - 252	51 - 99	CCW, fast → slow			
253 - 255	100	No rotation			
9	14	Rotating gobo, fine indexing (LSB)			
		<i>If indexed gobo is selected on channel 7 (basic) or 12 (extended)</i>			
0 - 255	0 - 100				

16-bit Basic Mode	16-bit Extended Mode	DMX Value	Percent	Function
10	15	Gobo wheel 2 (static gobos): gobo selection, wheel scroll, random gobo		
		<i>Continuous scroll</i>		
		0	0	Open
		0 - 10	1 - 3	Open → slot 1
		11	4	Slot 1 (Crackle)
		12 - 21	5 - 7	Slot 1 → slot 2
		22	8	Slot 2 (Triangles Small)
		23 - 32	9 - 12	Slot 2 → slot 3
		33	13	Slot 3 (Tye Dye)
		34 - 43	14 - 16	Slot 3 → slot 4
		44	17	Slot 4 (Globo)
		45 - 54	18 - 21	Slot 4 → slot 5
		55	21	Slot 5 (Worms)
		56 - 65	22 - 25	Slot 5 → slot 6
		66	26	Slot 6 (Bio)
		67 - 76	27 - 29	Slot 6 → slot 7
		77	30	Slot 7 (Leaf Breakup)
		78 - 87	31 - 33	Slot 7 → slot 8
		88	34	Slot 8 ("Les Mis" Whirl Pool)
		89 - 98	35 - 38	Slot 8 → slot 9
		99	39	Slot 9 (Two Tone)
		100 - 109	40 - 42	Slot 9 → open
		110 - 112	43	Open
		<i>Stepped scroll</i>		
		113 - 121	44 - 47	Slot 9 (Two Tone)
		122 - 130	48 - 51	Slot 8 ("Les Mis" Whirl Pool)
		131 - 139	52 - 54	Slot 7 (Leaf Breakup)
		140 - 148	55 - 58	Slot 6 (Bio)
		149 - 157	59 - 61	Slot 5 (Worms)
		158 - 166	62 - 65	Slot 4 (Globo)
		167 - 175	66 - 69	Slot 3 (Tye Dye)
		176 - 184	70 - 72	Slot 2 (Triangles Small)
		185 - 193	73 - 76	Slot 1 (Crackle)
194 - 202	77 - 79	Open		
<i>Continuous wheel rotation</i>				
203 - 221	80 - 87	CW, fast → slow		
222 - 240	88 - 94	CCW, slow → fast		
<i>Random gobo</i>				
241 - 245	95 - 96	Fast		
246 - 250	97 - 98	Medium		
251 - 255	99 - 100	Slow		
11	16	Static gobo/color wheel macros, random CMY		
		0 - 15	0 - 5	No macro
		16 - 55	6 - 21	Static gobo wheel shake, slow → fast
		56 - 95	22 - 37	Color wheel shake, slow → fast
		96 - 135	37 - 53	Static gobo wheel and color wheel shake, slow → fast
		<i>Random CMY (set min. or max. limits on channels 3, 4 & 5 (basic) or 4, 6 & 8 (extended))</i>		
		136 - 175	54 - 69	Fast
176 - 215	70 - 84	Medium		
216 - 255	85 - 100	Slow		
12	17	Gobo animation wheel: position and function		
		0 - 9	0 - 3	Open
		10 - 19	4 - 7	Horizontal indexed position: set indexing on 13 (basic) or 18 (extended)
		20 - 29	8 - 11	Vertical indexed position: set indexing on channel 13 (basic) or 18 (extended)
		30 - 39	12 - 15	Horizontal position, continuous rotation: set direction & speed on channel 13 (basic) or 18 (extended)
		40 - 49	16 - 19	Vertical position, continuous rotation: set direction & speed on channel 13 (basic) or 18 (extended)
		50 - 139	20 - 54	Indexed angled position, horizontal → vertical: set indexing on channel 13 (basic) or 18 (extended)
		140 - 229	55 - 89	Angled position, vertical → horizontal, continuous rotation: set direction & speed on channel 13 (basic) or 18 (extended)
230 - 255	90 - 100	Open		

16-bit Basic Mode	16-bit Extended Mode	DMX Value	Percent	Function
13	18	0 - 255	0 - 100	Gobo animation wheel: indexed angled position, rotation direction and speed <i>If indexed angled position is selected on channel 12 (basic) or 17 (extended)</i> Indexed angle, min.→ max.
		0 - 2	0	Continuous rotation: set angle on channel 12 (basic) or 17 (extended) No rotation
		3 - 127	1 - 50	CCW, slow → fast
		128 - 252	51 - 99	CW, fast → slow
		253 - 255	100	No rotation
14	19	0 - 19	0 - 7	Prism Prism off
		20 - 79	8 - 31	Prism on, CCW rotation, fast → slow
		80 - 89	31 - 35	Prism on, no rotation
		90 - 149	35 - 58	Prism on, CW rotation, slow → fast
		150 - 255	59 - 100	Prism off
15	20	0 - 199	0 - 77	Iris (MSB) Open → closed
		200 - 215	78 - 84	Closed
		216 - 229	85 - 89	Opening pulse, fast → slow
		230 - 243	90 - 94	Closing pulse, fast → slow
		244 - 246	95 - 96	Random opening pulse, fast
		247 - 249	97	Random opening pulse, slow
		250 - 252	98 - 99	Random closing pulse, fast
		253 - 255	100	Random closing pulse, slow
		-	21	0 - 255
16	22	0 - 255	0 - 100	Focus (MSB) Infinity → near
-	23	0 - 255	0 - 100	Focus, fine (LSB)
17	24	0 - 255	0 - 100	Zoom (MSB) Flood → spot
-	25	0 - 255	0 - 100	Zoom, fine (LSB)
18	26	0 - 255	0 - 100	Pan (MSB) Left → right (128 = neutral)
19	27	0 - 255	0 - 100	Pan, fine (LSB)
20	28	0 - 255	0 - 100	Tilt (MSB) Left → right (128 = neutral)
21	29	0 - 255	0 - 100	Tilt, fine (LSB)
22	30	0 - 2	0 - 1	Pan/tilt speed Tracking
		3 - 242	1 - 95	Fast → slow (vector control)
		243 - 245	96	Tracking, <i>PTSP = SLOW</i> (menu override)
		246 - 248	96 - 97	Tracking, <i>PTSP = NORM</i> (menu override)
		249 - 251	98	Tracking, <i>PTSP = FAST</i> (menu override)
		252 - 255	99 - 100	Blackout while moving

16-bit Basic Mode	16-bit Extended Mode	DMX Value	Percent	Function
23	31			Effects speed <i>Dimmer, CMY, animation wheel rotation, animation wheel angle, iris, zoom and focus</i>
		0 - 2	0 - 1	Tracking
		3 - 245	1 - 96	Fast → slow
		246 - 251	96 - 98	Tracking
		252 - 255	99 - 100	Maximum speed
				<i>Color wheel</i>
		0 - 2	0 - 1	Tracking
		3 - 245	1 - 96	Speed, fast → slow
		246 - 248	96 - 97	Tracking, SCUT = OFF (menu override)
		249 - 251	98	Tracking, SCUT = ON (menu override)
		252 - 255	99 - 100	Blackout while moving
				<i>Gobo selection, wheels 1 and 2</i>
		0 - 245	0 - 96	Normal (no blackout)
		246 - 248	96 - 97	Normal, SCUT = OFF (menu override)
		249 - 251	98	Normal, SCUT = ON (menu override)
		252 - 255	99 - 100	Blackout while moving
				<i>Gobo indexing, wheels 1 and 2</i>
		0 - 2	0 - 1	Tracking mode
		3 - 245	1 - 96	Fast → slow
		246 - 251	96 - 98	Tracking
		252 - 255	99 - 100	Blackout while moving
				<i>Prism</i>
		0 - 251	0 - 98	Normal (no blackout)
		252 - 255	99 - 100	Blackout while moving

Control menu

Menu	Item	Options	Notes (Default settings in bold print)
ADDR		1 - 490 (16-bit basic)	DMX address (new fixtures are supplied with address set to 1)
		1 - 482 (16-bit extended)	
PSET		16BT	16-bit basic DMX mode with 2-channel (coarse and fine) control of gobo rotation, pan, and tilt
		16EX	16-bit extended DMX mode with basic mode features plus fine control of dimmer, cyan, magenta, yellow, color wheel, iris, focus and zoom
PATI	SWAP	OFF	Normal pan and tilt control
		ON	Map DMX pan control to tilt channel and vice versa
	PINV	OFF	Normal pan control: left → right
		ON	Reverse DMX pan control: right → left
	TINV	OFF	Normal tilt control: up → down
		ON	Reverse DMX tilt control, down → up
PTSP		NORM	Normal pan/tilt speed
		FAST	Optimize pan/tilt movement for speed
		SLOW	Optimize pan/tilt movement for smoothness
EFSP		NORM	Normal effects speed
		FAST	Optimize effects movement for speed
		SLOW	Optimize effects movement for smoothness
		PTSS	Pan/tilt speed slave: effects speed copies the pan/tilt speed set via the control menu or via DMX
STUD		OFF	Optimize effects for speed
		ON	Optimize effects for silence (studio mode)
PERS	DISP	ON	Display remains on
		2 MN	Display extinguishes 2 minutes after last key press
		10MN	Display extinguishes 10 minutes after last key press
	DINT	AUTO	Display adjusts automatically for ambient light level
		100 - 10	Adjust display intensity manually
	DLOF	OFF	Disable lamp off via DMX
		ON	Enable lamp off via DMX
	DRES	ON	Enable reset via DMX
		OFF	Disable reset via DMX
		5SEC	Enable reset via DMX when reset command is held for 5 seconds
	ALON	OFF	No automatic lamp strike
		ON	Lamp strikes automatically within 90 seconds of power on
		DMX	Lamp strikes if DMX is present, douses after 15 mins. without DMX
	SCUT	ON	Gobo and color wheels turn shortest distance (across open)
		OFF	Gobo and color wheels do not cross open
	DICU	DIM1	Dimmer curve simulates tungsten incandescent bulb characteristics
		DIM2	Near-linear dimmer curve
	CMYB	OFF	Disable CMY blackout
ON		Enable CMY blackout	
IRIB	OFF	Disable iris blackout	
	ON	Enable iris blackout	

Table 2: Control menu

Menu	Item	Options	Notes (Default settings in bold print)
DFSE	FACT	LOAD	Return all settings (except calibrations) to factory defaults
	CUS 1, CUS2, CUS3	LOAD	Load custom configuration
		SAVE	Save current custom configuration
INFO	TIME→HRS	TOTL	Total hours of operation since manufacture
		RSET	Hours of operation since counter reset (see page 13)
	TIME→L HR	TOTL	Total hours of operation with lamp on since manufacture
		RSET	Lamp hours since counter reset (see page 13)
	TIME→L ST	TOTL	Total number of lamp strikes since manufacture
		RSET	Number of lamp strikes since counter reset (see page 13)
	TEMP	HEAD	Head temperature
		LAMP	Base temperature
		PCB	Circuit board temperature
		SMPS	Switch mode power supply temperature
VER	X.X.X	CPU firmware version	
DMXL	RATE		DMX transmission speed in packets per second
	QUAL		Percent of packets received
	STCO		Value of the DMX start code
	SHUT - EFSP		DMX value (0 - 255) received on each channel Values for fine control channels (indicated with F in the display) can only be viewed if available in the DMX mode the fixture is set to

Table 2: Control menu

Menu	Item	Options	Notes (Default settings in bold print)	
MAN	RST		Reset fixture	
	L ON		Lamp on	
	L OFF		Lamp off	
	SHUT	OPEN		Open shutter
		CLOS		Close shutter
		STRF		Fast strobe
		STRM		Medium strobe
		STRS		Slow strobe
	DIM	0-255	Dimmer	
	CYAN	0-255	Cyan	
	MAG	0-255	Magenta	
	YEL	0-255	Yellow	
	COL	OPEN		Color wheel: open position
		C 1-C8		Color wheel: filters 1-8
		CW F-CCWS		Color wheel continuous rotation: CW and CCW; fast, medium and slow
		RND F-RND S		Color wheel random rotation: fast, medium and slow
	GOB 1	OPEN		Gobo wheel 1 (rotating gobo wheel): open position
		G 1 I-G 6 I		Rotating gobos 1 - 6: indexed position
		G 1 R-G 6 R		Rotating gobos 1 - 6: continuous rotation
		G 1RS-G 6RS		Rotating gobos 1 - 6: rotation and shake
		CW F-CCWS		Gobo wheel 1: scroll CW and CCW; fast, medium and slow
	RG 1	0-255	Rotating gobo wheel: scroll	
	RG 1F	0-255	Rotating gobo wheel: scroll (fine)	
	GOB 2	OPEN		Gobo wheel 2 (static gobo wheel): open position
		G 1-G 9		Static gobos 1 - 9
		CW F-CCWS		Gobo wheel 2 scroll: CW and CCW; fast, medium, slow and random
		RND F-RND S		Gobo wheel 2 random scroll: fast, medium and slow
	GOMA	NONE-MAC 3	Gobo macros 1 - 3	
	ANIP	OPEN		Animation wheel open position
		HP I		Animation wheel horizontal position (indexing)
		V P I		Animation wheel vertical position (indexing)
		HP R		Animation wheel horizontal position (rotation)
		V P R		Animation wheel vertical position (rotation)
		SPI 1-SPI 4		Animation wheel angled position 1-4 (indexing)
		SPR 1-SPR 4		Animation wheel angled position 4-1 (rotation)
	ANIR	0-255	Animation wheel position (indexing) or speed (rotation)	
	PRIS	OFF		Prism off
		ON		Prism on, no rotation
		CW F-CCWS		Prism on: rotation CW and CCW; fast, medium and slow

Table 2: Control menu

Menu	Item	Options	Notes (Default settings in bold print)
MAN (cont.)	IRIS	0- > C	Iris diameter: Press [Enter], then use up and down arrows to select a value from 0 - 200
		CLSD	Iris closed
		PLOF	Fast opening pulse
		PLOS	Slow opening pulse
		PLCF	Fast closing pulse
		PLCS	Slow closing pulse
		RDOF	Fast random opening pulse
		RDOS	Slow random opening pulse
		RDCF	Fast random closing pulse
		RDCS	Slow random closing pulse
	FOC	0 - 255	Focus position
	ZOOM	0 - 255	Zoom position
	PAN	0 - 255	Pan position
PANF	0 - 255	Pan position (fine)	
TILT	0 - 255	Tilt position	
TLTF	0 - 255	Tilt position (fine)	
TSEQ		RUN	Run a general test of all effects
UTIL To access this menu, hold [Enter] pressed for a few seconds	FEBA	ON	Enable pan/tilt position correction system. See page 14
		OFF	Disable pan/tilt feedback. Setting not saved
	EFFB	ON	Enable position feedback from rotating effects. See page 14
		OFF	Disable position feedback from rotating effects. Setting not saved
	ADJ		See "Adjustment submenu" on page 39
	CAL (OF = offset)	P OF	Pan calibration (adjustment range: 1 - 255)
		T OF	Tilt calibration (adjustment range: 70 - 186)
		D OF	Dimmer calibration (adjustment range: 90 - 170)
		C OF	Cyan calibration (adjustment range: 1 - 255)
		M OF	Magenta calibration (adjustment range: 1 - 255)
		Y OF	Yellow calibration (adjustment range: 1 - 255)
		COOF	Color wheel calibration (adjustment range: 118 - 138)
		G1OF	Gobo wheel 1 (rotating gobos) calibration (adjustment range: 118 - 138)
		G2OF	Gobo wheel 2 (static gobos) calibration (adjustment range: 118 - 138)
		FOOF	Focus calibration (adjustment range: 98 - 158)
		ZOOF	Zoom calibration (adjustment range: 98 - 158)
		IROF	Iris calibration (adjustment range: 128 - 255)
		PROF	Prism calibration (adjustment range: 116 -140)
	DFOF	SURE	Set all effects to calibration value 128
	PCBT		PCB test: for service use only
	FANS	FULL	Cooling fans: full speed
		REG	Cooling fans: temperature regulated
	UPLD	SURE	Manually set fixture to software update mode

Table 2: Control menu

Adjustment submenu

The *UTIL*→*ADJ* menu is for use by service technicians when performing adjustments.

Menu	Item	Item	Options	Notes	
<i>RST</i>				Reset fixture	
<i>L ON</i>				Strike lamp	
<i>L OFF</i>				Douse lamp	
<i>HEAD</i>	<i>DIMM</i>	<i>DIM</i>	<i>ADJ</i>	Dimmer blades against stop	
			<i>CLOS</i>	Close dimmer	
			<i>OPEN</i>	Dimmer to open position	
			<i>ST S</i>	Strobe slow	
			<i>ST M</i>	Strobe medium	
			<i>ST F</i>	Strobe fast	
		<i>CYAN</i>	<i>ON S</i>	Cyan flag on switch (retracted position)	
			<i>MIN</i>	Minimum cyan position	
			<i>MAX</i>	Maximum cyan position	
		<i>MAG</i>	<i>ON S</i>	Magenta flag on switch (retracted position)	
			<i>MIN</i>	Minimum magenta position	
			<i>MAX</i>	Maximum magenta position	
		<i>YEL</i>	<i>ON S</i>	Yellow flag on switch (retracted position)	
			<i>MIN</i>	Minimum yellow position	
			<i>MAX</i>	Maximum yellow position	
		<i>TEST</i>			Test dimmer and CMY effects
		<i>TOOL</i>			For service use only
		<i>EFFM</i>	<i>COL</i>	<i>OPEN - CB</i>	Color wheel full positions
	<i>CW F - RND S</i>			Color wheel rotation	
	<i>GOB 1</i>		<i>OPEN - GG I</i>	Gobo wheel 1 (rotating gobos) gobo selection (indexing)	
			<i>G 1 R - GG R</i>	Gobo selection and rotation	
			<i>G 1RS - GGRS</i>	Gobo selection, rotation and shake	
			<i>CW F - CCWS</i>	Gobo wheel 1 scroll: speed and direction	
	<i>GOB 2</i>		<i>OPEN - G9</i>	Gobo wheel 2 (static gobos) gobo selection (indexing)	
			<i>CW F - RND S</i>	Gobo wheel 2 scroll: speed and direction	
	<i>ANIW</i>		<i>OPEN</i>	Animation wheel open	
			<i>HP I - VP R</i>	Animation wheel horizontal/vertical position, indexed/rotation	
			<i>SPI 1 - SPI 4</i>	Animation wheel angled position 1-4, indexed	
			<i>SPR 1 - SPR 4</i>	Animation wheel angled position 1-4, rotation	
	<i>IRIS</i>		<i>O - > C</i>	Iris diameter: press [Enter], then use up and down arrows to select a value from 0 - 200	
			<i>CLS D</i>	Iris closed	
			<i>PLOF - PLCS</i>	Pulse: opening fast - closing slow	
			<i>RPOF - RPCS</i>	Random pulse: opening fast - closing slow	
	<i>TEST</i>			Test all effects in effects module	

Table 3: Adjustment submenu

Menu	Item	Item	Options	Notes	
HEAD cont.	ZFPM	TOOL		For factory use	
		PRIS	OFF	Prism, zoom, and focus to adjustment positions	
			DN	Prism in	
			CW F – CCWS	Prism rotation: direction and speed	
		ZOOM	ZI S – ZO F		Zoom: in/out, speed
		ZFPT	POUT		Zoom/focus/prism test: prism out
			PIN		Zoom/focus/prism test: prism in
		FOCU	FI S – FO F		Focus: near/far, speed
TEST		Test zoom, focus, and prism			
PATI	NEUT		Move pan and tilt to neutral positions		
	PNTD		Pan neutral, tilt down		
	PNTU		Pan neutral, tilt up		
	PLTN		Pan left, tilt neutral		
	PRTN		Pan right, tilt neutral		
	PLTD		Pan left, tilt down		
	PRTU		Pan right, tilt up		

Table 3: Adjustment submenu

Control menu shortcuts

The following shortcuts are available using the buttons in the MAC 700 Profile control panel:

Shortcut	Function
Hold [Menu] and press [Up]	Resets fixture
Hold [Enter] and press [Up]	Strikes lamp
Hold [Enter] and press [Down]	Douses lamp
Hold [Menu] and [Enter] while applying power	Freezes pan and tilt
Hold [Up] and press [Down]	Invert display

Table 4: Control menu shortcuts

Service messages

MSG (when service message LED is lit)	REPLACE LAMP	Displayed when lamp hours exceed average life (750 hours)
	FIXTURE OVERHEATING	Displayed if head temperature exceeds 85° C (185° F)

Table 5: Service messages

Display messages

Message	Appears when...	What to do
<i>RST</i> (Reset)	... the fixture is indexing effects at startup.	Wait for reset to complete.
<i>SRST</i> (Serial reset)	... the fixture has received a reset command.	Wait for reset to complete. Note that you can set <i>PERS</i> → <i>DRS</i> to <i>OFF</i> to prevent accidental DMX reset commands.
<i>HOME</i>	... the effects have been indexed and are moving to their default positions.	Wait a few moments.
<i>DDOR</i>	...the lamp access cover is not fully closed.	Check that the lamp access cover is locked in place.
<i>LERR</i> (Lamp error)	... the lamp does not ignite within 30 seconds of receiving the 'Lamp ON' command. Likely reasons are a missing or defective lamp, or insufficient AC voltage.	Check the lamp. Check that the voltage and frequency settings match the local supply.
<i>MERR</i> (Memory error)	...the EEPROM memory cannot be read.	Contact Martin service personnel for assistance.
<i>CSER</i> (Check-sum error)	...a software upload is unsuccessful.	Reload software.
	... there is no communication between the control panel and motherboard. This readout appears briefly when switching on the fixture.	Check fuses and replace accordingly. Check that cable between control panel and motherboard is connected properly. Reinstall software.
<i>SHER</i> (Short error)	... the fixture detects the lamp is ON but no 'Lamp ON' command has been received. This can occur if the lamp relay is stuck or if the lamp-power feedback circuit fails. The fixture may be operated but remote lamp on/off may be affected.	Contact Martin service personnel for assistance.
<i>BTER</i> (Base temperature sensor error) <i>HTER</i> (Head temperature sensor error) <i>LTER</i> (Lamp temperature sensor error) <i>ETER</i> (Switchmode/ballast side temperature sensor error)	...there is a malfunction in the temperature sensing circuit.	Contact Martin service personnel for assistance.
<i>FBER</i> (Feedback error pan) <i>FBER</i> (Feedback error tilt) <i>FBER</i> (Feedback error pan/tilt)	...there is a malfunction in the optical pan/tilt monitoring circuit (e.g. sensor defective). After a time-out, the effect in question stops in a random position.	Reset fixture. Contact Martin service personnel if problem continues.
<i>LTCO</i> (Lamp temperature cut-out)	... the lamp temperature is too high and thermal protection circuits cut power to the lamp.	Allow fixture to cool. Ensure nothing is obstructing airflow around fixture. Clean air vents, air filters and fans. Reduce ambient temperature. Contact Martin service personnel if problem continues.
<i>PRER</i> (Pan time-out) <i>TIER</i> (Tilt time-out) <i>FDER</i> (Focus time-out) <i>ZDER</i> (Zoom time-out)	...there is a malfunction in the electric indexing circuit for pan, tilt, focus or zoom. The fixture will, after the time-out, establish a mechanical stop, and continue to work normally.	Reset fixture. Contact Martin service personnel if problem continues.
<i>CDER</i> (Color wheel time-out)) <i>G1ER</i> (Gobo wheel 1 time-out) <i>G2ER</i> (Gobo wheel 2 time-out) <i>RGER</i> (Gobo wheel rotation time-out) <i>APER</i> (Animation wheel position time-out) <i>ARER</i> (Animation wheel rotation time-out)	...there is a malfunction in the magnetic-indexing circuit (e.g. sensor defective or magnet missing). After the time-out, the effect in question stops in a random position.	Reset fixture. Contact Martin service personnel if problem continues.
<i>CYER</i> (Cyan time-out) <i>MAER</i> (Magenta time-out)) <i>YEER</i> (Yellow wheel time-out)	...there is a malfunction in the electric indexing circuit for one of the CMY flags.	Reset fixture. Contact Martin service personnel if problem continues.

Table 6: Display messages

Message	Appears when...	What to do
<i>RAME</i>	...there is an onboard RAM memory error.	Contact Martin service personnel for assistance.
<i>OPER</i>	...there is an onboard programming error.	Contact Martin service personnel for assistance.

Table 6: Display messages

Troubleshooting

Problem	Probable cause(s)	Remedy
One or more of the fixtures is completely dead.	No power to fixture.	Check that power is switched on and cables are plugged in.
	Primary fuse blown (located near mains inlet).	Isolate fixture from power and replace fuse.
	Secondary fuse(s) blown (located on PCBs in base).	Isolate fixture from power. Check fuses and replace.
Fixtures reset correctly but respond erratically or not at all to the controller.	Bad data link.	Inspect connections and cables. Correct poor connections. Repair or replace damaged cables.
	Data link not terminated.	Insert termination plug in output jack of the last fixture on the link.
	Incorrect addressing of the fixtures.	Check fixture address and protocol settings.
	One of the fixtures is defective and disturbs data transmission on the link.	Unplug the XLR in and out connectors and connect them directly together to bypass one fixture at a time until normal operation is regained. Have the fixture serviced by a qualified technician.
	XLR pin-out on fixtures does not match (pins 2 and 3 reversed).	Install a phase-reversing cable between the fixtures or swap pins 2 and 3 in the fixture that behaves erratically.
Time out error after fixture reset.	Effect requires mechanical adjustment.	Disable effects feedback (page 14). Contact Martin technician for service.
Mechanical effect loses position.	Mechanical train requires cleaning, adjustment, or lubrication.	Contact Martin technician for service.
Lamp fails to strike after turning the fixture off and on again, or after a power failure.	Electronic ballast does not recognize that the lamp is off.	Send LAMP OFF command before sending another LAMP ON command. The lamp will then strike. See protocol for override if <i>DLOF</i> is set to <i>OFF</i>
No light and <i>LERR</i> (lamp error) message displayed.	Lamp blown	Disconnect fixture and replace lamp.
	Lamp not installed	Disconnect fixture and install lamp.
	Lamp access safety switch open	Verify that lamp access plate is fully seated and locked in place.
Lamp cuts out intermittently.	Fixture is too hot.	Allow fixture to cool. Clean fixture. Reduce ambient temperature.

Table 7: Troubleshooting

Circuit board connections

S1	
S2	Ballast FB
S3	Pan
S4	Tilt
S5	Gobo 1
S6	Gobo 1 Rot.
S7	Focus Sw.
S8	Zoom Sw.
S9	Cyan
S10	Magenta
S11	Ani. Pos.
S12	Ani. Rot.
S13	Gobo 2
S14	Door switch
S15	Yellow
S16	Color 2

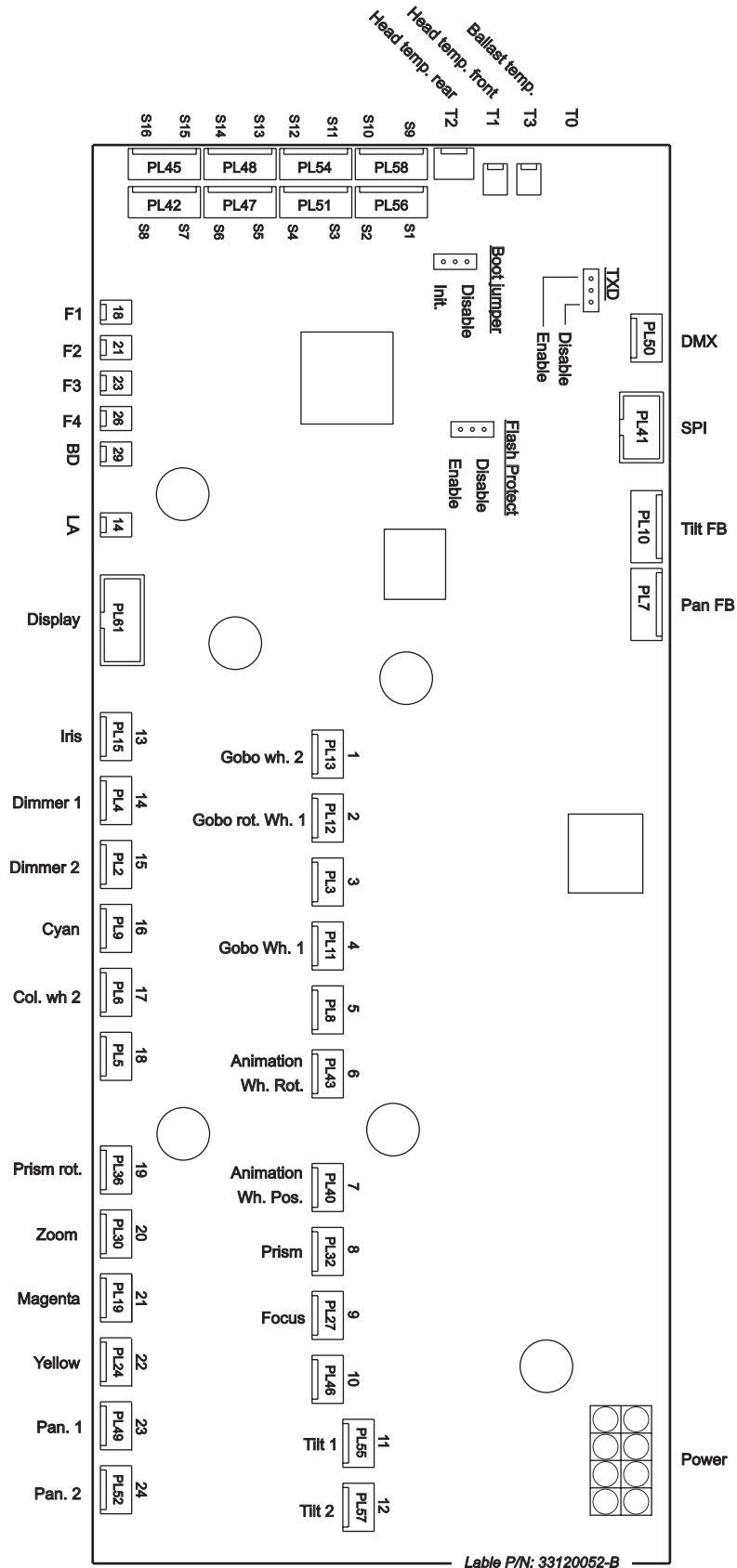

MAC 700 Profile Specifications

PHYSICAL

Length	450 mm (17.7 in)
Width	365 mm (14.4 in)
Height	636 mm (25.0 in)
Weight	34.5 kg (76.1 lbs)

SOURCE

Lamp	700 W short arc discharge
Base	Double-ended SFC 10-4 with key
Approved models	OSRAM HTI 700/D4/75
Ballast	electronic

THERMAL

Maximum ambient temperature (T_a)	40° C (104° F)
Maximum surface temperature	160° C (320° F)
Low noise cooling with fan speed regulation mode	
Total heat dissipation (calculated, 230 V, 50 Hz / 110 V, 60 Hz)	3190 BTU/hr / 3429 BTU/hr

PHOTOMETRICS

Measurement conditions	.230 V, 50 Hz; no effects applied
Measurement test source	OSRAM HTI 700/D4/75

Photometrics: minimum spread with diffuser

Total output	14300 lumens
One-tenth peak output	14300 lumens
Cutoff angle	16.0°
One-tenth peak angle	15.0°

Photometrics: median spread with diffuser

Total output	14600 lumens
One-tenth peak output	14600 lumens
Cutoff angle	20.2°
One-tenth peak angle	19.4°

Photometrics: maximum spread with diffuser

Total output	14700 lumens
One-tenth peak output	14700 lumens
Cutoff angle	30.0°
One-tenth peak angle	29.0°

Photometrics: minimum spread without diffuser

Total output	16200 lumens
One-tenth peak output	16200 lumens
Cutoff angle	15.8°
One-tenth peak angle	15.1°

Photometrics: median spread without diffuser

Total output	16500 lumens
One-tenth peak output	16500 lumens
Cutoff angle	20.2°
One-tenth peak angle	19.5°

Photometrics: maximum spread without diffuser

Total output	16700 lumens
One-tenth peak output	16600 lumens
Cutoff angle	30.6°
One-tenth peak angle	29.6°

OPTICS

Glass cold light reflector	
Spread angle	14° - 30° (focused on open gobo)
Focal length	46 - 100 mm

ELECTRICAL

AC input	3 m trailing cable w/o cord cap
Operating ranges	100-130/200-250 VAC, 50/60 Hz
Power supply	auto-ranging electronic switch-mode
Main fuse for 200 - 250 V power	6.3 AT, P/N 05020020
Main fuse for 100 - 130 V power	15 AT, P/N 05020027

Typical power and current

@ 100 V, 60 Hz	1019 W, 10.3 A, PF 0.996
@ 120 V, 60 Hz	988 W, 8.3 A, PF 0.995
@ 208 V, 60 Hz	949 W, 4.7 A, PF 0.976
@ 230 V, 50 Hz	944 W, 4.2 A, PF 0.973
@ 240 V, 50 Hz	940 W, 4.0 A, PF 0.970
@ 250 V, 50 Hz	940 W, 3.9 A, PF 0.966

V = volts, Hz = hertz, W = watts, A = amps, PF = power factor

Note: Allow for a deviation of +/- 10% from typical figures listed above. Measurements made at nominal voltage. Local supply voltages can vary by +/- 10%.

CONTROL AND PROGRAMMING

Protocol	USITT DMX-512 (1990)
Control channels	23 or 31
Receiver	Opto-isolated RS-485
Data I/O	locking 3-pin & 5-pin XLR, pin 1 shield, pin 2 cold (-), pin 3 hot (+)
Setting and addressing	LED control panel or MP-2 uploader
Movement control	tracking and vector
Software installation	serial upload (MUF)

ELECTROMECHANICAL EFFECTS

Beam effects

High speed replaceable rotating 3 facet prism, 8-bit control
Motorized iris, 8- or 16-bit control

Dimmer/shutter

Full-range dimming, 8- or 16-bit control
Shutter speed: flash variable 2hz to 10hz, 8-bit control

Color

1 motorized color wheel with 8 replaceable dichroic color filters, plus open, 8- or 16-bit control

CMY

Cyan: 0-100%, 8- or 16-bit control
Magenta: 0-100%, 8- or 16-bit control
Yellow: 0-100%, 8- or 16-bit control

Pan/tilt

Pan: 540°, 16-bit control
Tilt: 246°, 16-bit control
Position correction system

Gobos

Rotating gobos: 6 positions plus open with continuous and indexed rotation, 16-bit control
Static gobos: 9 positions plus open, 8-bit control

Gobo animation wheel

Vertical, horizontal or angled animation effects.
Indexed and variable speed continuous rotation, 8- or 16-bit control

Focus

Motorized focus: 2m to infinity, 8- or 16-bit control

Zoom

14° - 30°, 8- or 16-bit control

GOBOS

Outside diameter	27.9 +0/-0.3 mm
Maximum image diameter	23 mm
Maximum thickness	1.1 mm in static slots, 4 mm in rotating slots
Recommended glass	high-temperature Borofloat or better with dichroic or enhanced aluminum coating
Recommended metal	0.5 mm aluminum

GOBO ANIMATION WHEEL

Outside diameter	116 mm +0/-0.25 mm
Image outer diameter	112 mm
Image inner diameter	32 mm
Construction	0.5 mm aluminum or textured glass with magnet

APPROVALS



EU EMC	EN 55 103-1, EN 55 015, EN 61 547
EU safety	EN 60598-2-17
US safety	ANSI/UL 1573
Canadian safety	CSA C22.2 NO 166

CONSTRUCTION

Housing	UV-resistant fiber-reinforced composite shell
Colors	black
Protection factor	IP 20
Shock resistant chassis	
Ergonomic carrying handles	

INSTALLATION

Mounting points	2 pairs of 1/4-turn locks
Orientation	any
Minimum distance from illuminated surface	1.2 m (48 in.)
Minimum distance from combustible materials	0.5 m (20 in.)

INCLUDED ITEMS

Lamp	OSRAM HTI 700/D4/75 (installed): P/N 97010212
Dichroic color filters	8 (installed)
Gobos	14 metal and 1 glass (installed), 5 extra metal gobos and extra spring
Gobo animation wheel	Radial breakup (installed): P/N 62325048
Fuse for use with 200 - 250 V power	6.3 AT fuse (installed): P/N 05020020
Fuse for use with 100 -130 V power	15 AT fuse: P/N 05020027
2 omega clamp attachment brackets with quarter-turn fasteners	2 x P/N 91602001
3-pin XLR cable, 5m	P/N 11820008
User manual	P/N 35000137

ACCESSORIES

Spiral breakup gobo animation wheel	P/N 62325049
Linear breakup gobo animation wheel	P/N 62325050
Coarse tangential gobo animation wheel	P/N 62325051
Cloud breakup gobo animation wheel	P/N 62325094
Elliptical breakup gobo animation wheel	P/N 62325095
Half-coupler clamp	P/N 91602005
G-clamp	P/N 91602003
DABS 1 Uploader	P/N 91611144
MP-2 Uploader	P/N 90758420
MAC 500/550/700 stock gobos	see www.martin.com

ORDERING INFORMATION

MAC 700 Profile in cardboard packing case	P/N 90207000
MAC 700 Profile in flight case	P/N 90207001

